

An IoT-based smart home automation system: Enhancing security, energy efficiency, and remote accessibility



Md. Mohiuddin Maruf^a  | Touhid Bhuiyan^b  | Erin Jahan Eshita^a  | Md. Sazzad Hossen^a  |
Md. Hafizul Imran^{ab}  

^aDepartment of Software Engineering, Daffodil International University, Birulia, Savar, Dhaka-1216, Bangladesh.

^bSchool of Information Technology, Washington University of Science and Technology, VA, United States.

Abstract The increasing demand for energy-efficient, secure, and remotely accessible home automation systems has led to the advancement of IoT-based smart home solutions. This study presents a comprehensive IoT-based home automation system integrating multiple sensor nodes and a central control unit to enhance safety, energy efficiency, and user convenience. The system comprises five nodes: a Combustion Accident Warning Node (CAWN), a Weather Sensing & Regulation Node (WSRN), a Remote Domestic Appliances Operate Node (RDAON), an Automate Light Control Node (ALCN), and a Home Defense Node (HDN). The ESP32 microcontroller serves as the control hub, communicating with all nodes through Wi-Fi and Bluetooth for real-time monitoring and control. The proposed system utilizes infrared flame sensors, gas sensors, temperature and humidity sensors, LDRs, and relays to automate household appliances and security mechanisms. Experimental results indicate that the system reduces energy consumption by 33.7% compared to manual control and 22.2% compared to traditional timer-based automation, leading to significant cost savings. The Home Defense Node demonstrates over 90% intrusion detection accuracy with a response time of 100–300 ms, ensuring robust security. Additionally, real-time cloud integration via the Blynk IoT platform enables seamless remote operation. The findings suggest that the proposed smart home system offers a reliable, and scalable solution for modern home automation.

Keywords: IoT, home automation, remote controlling, system architecture, home automation software

1. Introduction

The Internet of Things (IoT) is revolutionizing several industries by allowing physical devices to be connected to the digital world. In healthcare (Nagayo et al., 2024), IoT enables smart medical devices, remote patient monitoring, and real-time health data collection. This enhances patient care and increases operational efficiency. In agriculture (Muthmainnah et al., 2024; Maslan et al., 2025), IoT supports precision farming through smart sensors that track soil moisture, weather, and crop health. This helps farmers use resources more efficiently and boosts productivity. IoT enhances wireless communication (Katariya et al., 2024) by enabling fast and seamless data exchange between devices through advanced networks like 5 G . This technology supports smart cities and industrial automation. The IoT is impacting many aspects of daily living. Home automation is one of them.

Home automation has been revolutionized by the Internet of Things (IoT) (Singh et al., 2018; Imran et al., 2022). Traditional home automation systems primarily relied on wired connections and manual controls, limiting their scalability, flexibility and energy efficiency. However, the integration of IoT technologies has enabled the development of smart home systems that allow real-time monitoring, remote control, and intelligent automation of household appliances (Atzori et al., 2010). These systems improve convenience, save energy, enhance security (Mahi et al., 2023), and offer a better quality of life. At present, the home automation market is worth 52.65 billion USD. By 2029, it is expected to grow to 66.45 billion USD (MarketsandMarkets, n.d.).

A modern home automation system should address critical challenges, including energy wastage, security threats and the requirement for remote accessibility. Many current systems are not flexible, energy-efficient, or affordable, making them less accessible. Furthermore, traditional systems depend on manual controls or fixed schedules and cannot adjust to changes in the environment or user habits. To overcome these limitations, this study proposes an IoT-based home automation system that integrates several sensor nodes and a centralized control unit to automate home appliances, improve security, and monitor the environment.

The proposed system consists of five functional nodes: the Combustion Accident Warning Node (CAWN) for fire and gas detection, the Weather Sensing & Regulation Node (WSRN) for monitoring and controlling room temperature and humidity,

the Remote Domestic Appliances Operate Node (RDAON) for remote operation of household devices, the Automate Light Control Node (ALCN) for intelligent lighting control and the Home Defense Node (HDN) for intrusion detection. These nodes communicate with a central ESP32-based control unit. The control unit processes sensor data and makes real-time decisions. The system uses Wi-Fi and Bluetooth, allowing users to control home appliances remotely through the Blynk IoT platform. The system also enhances safety by detecting fire and gas detection mechanisms. The Combustion Accident Warning Node (CAWN) utilizes infrared flame sensors and gas sensors to identify hazardous situations. When a risk is detected, it triggers an alarm to prevent fire accidents. The system uses advanced technology, such as infrared radiation analysis for flame detection and semiconductor-based gas sensing, ensuring high reliability and accuracy in hazard identification. The findings of this research contribute to the growing field of IoT-based smart home systems, offering a practical and scalable solution for enhancing home security, energy efficiency, and automation.

This paper is organized as follows: Section 2 presents the literature review, discussing existing home automation solutions and their limitations. The suggested system architecture is explained in Section 3, along with a breakdown of its constituent parts and features. The implementation processes are described in Section 4 and the experimental results are then covered in Section 5. Finally, Section 6 concludes the study, highlighting the system's benefits and potential future improvements.

2. Literature Review

The development of home automation systems has evolved significantly with the integration of Internet of Things (IoT) technologies. Numerous studies have focused on enhancing smart homes by incorporating wireless communication, cloud platforms, and artificial intelligence (AI) to enable intelligent control of appliances and security systems. These systems typically aim to address challenges such as energy inefficiency, limited scalability, inadequate security, and poor remote accessibility. In this section, we critically examine existing IoT-based home automation solutions with respect to their architectural design, sensor integration, communication protocols, cost-efficiency, scalability, and deployment complexity. The goal is to identify key limitations in current approaches and highlight the novel contributions of our proposed system in comparison.

IoT-driven home automation systems are designed to connect household appliances and security devices to a centralized control unit, enabling automation and remote control. Several studies have proposed different architectures for smart home systems. The authors (Asadullah & Ullah, 2017) proposed a Bluetooth Low Energy (BLE) home automation system, but its short-range connectivity and limited scalability (1 device) hinder practicality. In contrast, our system uses ESP32 microcontrollers with built-in Wi-Fi and Bluetooth 4.2, offering long-range connectivity, higher scalability (multiple clients), and lower cost (~\$5 vs. \$7 for BLE). BLE requires separate modules, adding complexity, while ESP32 simplifies deployment. Our system thus enhances flexibility, reduces cost, and supports broader applications compared to earlier BLE-based solutions.

Energy conservation is a key motivation behind modern home automation systems. Several studies have explored adaptive control mechanisms to minimize energy wastage. The authors (Pradhan et al., 2021) proposed an LDR-based smart lighting system that reduced energy use but lacked remote access for customization. Our system addresses this by integrating the Blynk IoT platform, enabling real-time remote control with minimal deployment complexity. This enhances user flexibility and scalability while maintaining energy efficiency, offering a more practical and user-friendly solution.

The authors (Mudgil & Rajoriya, 2024) developed an IoT-based system for monitoring temperature, humidity, and gas levels, displaying real-time data but lacking control functionalities. Our proposed system advances this by integrating monitoring with active control of temperature and humidity using additional equipment like fans. While this increases cost and deployment complexity, it enables greater scalability and flexibility. It also combines smart lighting and appliance control, reducing power consumption by 33.7%.

Home security is a primary concern in IoT-based smart home solutions. Researchers have explored various intrusion detection methods, including laser-based barriers, motion sensors, and AI-powered surveillance systems. The authors (Saeed et al., 2019) proposed a sensor-based home security system using motion sensors and microwave technology, which effectively detects intrusions but suffers from delayed response and reduced accuracy in real-world use. Our Home Defense Node (HDN) addresses these issues by combining laser and sensor-based detection, achieving 90% accuracy with a fast 100–300 ms response time. Moreover, while their prototype costs around \$8, ours is more cost-effective at \$1. HDN is also easily scalable based on user needs, offering a more efficient and affordable solution.

The ability to remotely control home appliances is a fundamental feature of IoT-based automation systems (Hafizul Imran et al., 2021; Asha et al., 2024). Several studies have explored different communication protocols for efficient remote operation. The authors (Danbatta & Varol, 2019) compared wireless protocols for smart homes, noting Wi-Fi's real-time performance and affordability, while Z-Wave offered better overall features but at higher cost. Our system adopts Wi-Fi using the ESP32 microcontroller, enabling reliable, low-cost, and long-range connectivity. Through the Blynk IoT platform, users gain real-time appliance control, ensuring ease of deployment, scalability, and enhanced user experience in home automation.

Fire and gas leak detection are critical components of smart home safety systems. Various studies have proposed different sensor-based approaches for early hazard detection. To address this, (Annuar et al., 2019) integrated an MQ2 gas sensor for LPG leak detection and achieved high accuracy with phone notifications. However, fire detection was not addressed.

Our proposed system combines IR flame and MQ2 gas sensors with real-time monitoring via the Blynk IoT platform, enabling accurate fire hazard detection and instant alerts. Though our system incurs higher costs due to additional components and platform fees, it offers greater scalability and ease of deployment. Unlike prior works, our system emphasizes comprehensive hazard detection, user accessibility, and practical deployment, ensuring a more robust and scalable safety solution.

Similarly, (Obayuwana et al. 2024) proposed an IoT-enabled fire detection system utilizing low-cost ESP32 cameras and a cloud-based convolutional neural network (CNN) for real-time flame detection. While their system demonstrated high accuracy (99.6%) and scalability. But their system lacked a gas detection component, limiting its ability to detect combustible gas leaks.

Based on the review of existing literature, several research gaps have been identified:

1. Limited integration of security and automation – Many existing systems focus on either energy efficiency or security, but few solutions effectively combine both.
2. Lack of fail-safe mechanisms – Many IoT-based systems rely solely on internet connectivity, making them vulnerable to network failures.

The literature review highlights the advancements in IoT-based home automation while identifying key limitations in existing solutions. This study contributes to the field by proposing a multi-functional, energy-efficient, and secure home automation system, integrating remote accessibility, hazard detection, and smart appliance control. By addressing critical research gaps, this system provides a practical and scalable alternative for modern home automation.

3. Materials and Methods

3.1. System Architecture Description

(Figure 1) displays the proposed architecture for the Smart Home System prototype. This architecture includes a Control Unit and 5 nodes. These nodes are a Combustion Accident Warning Node (CAWN), a Weather Sensing & Regulation Node (WSRN), a Remote Domestic Appliances Operate Node (RDAON), an Automated Light Control Node (ALCN), and a Home Defense Node (HDN). This system can control different home appliances of ratings 220V and 5A in the user's home over the internet.

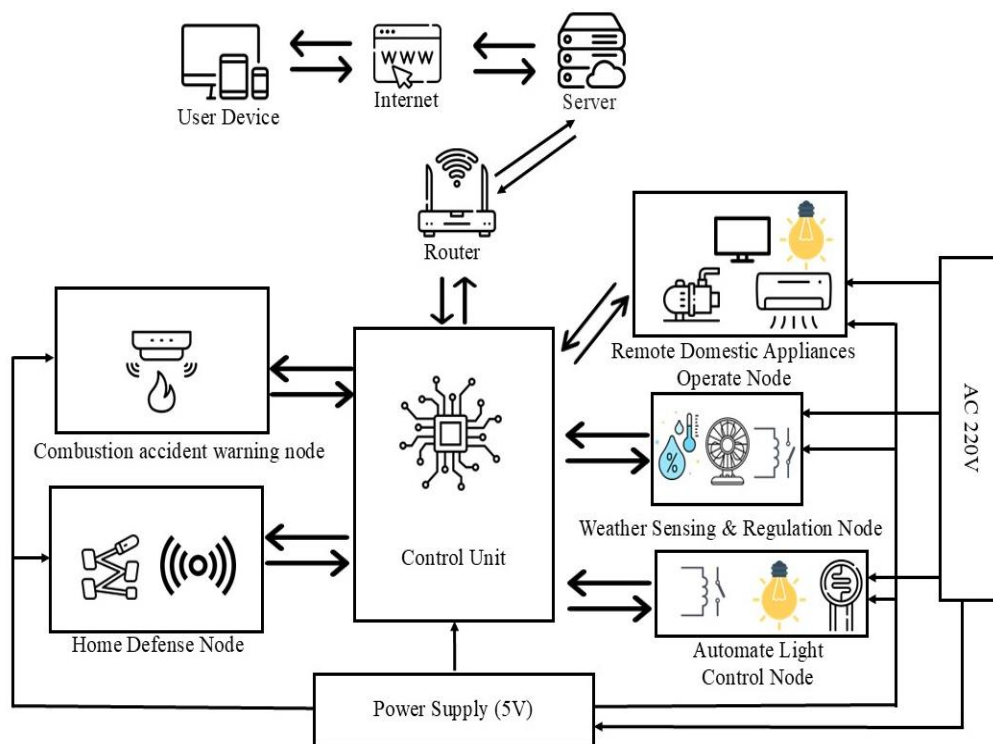

Figure 1 Architecture of the proposed system.

3.1.1. Control Unit

The ESP32 has been selected as the control unit in the proposed system due to its functionality as a system-on-chip microcontroller, which is integrated with Wi-Fi and dual-mode Bluetooth capabilities (Babiuch et al., 2019). The Wi-Fi module helps to connect cloud server through the internet. Bluetooth helps in wireless communication within a specific area. The

control unit collect data from the input device (e.g., sensor) and make decision according to the internal logic. Then sent this decision to the user. (Figure 2) illustrates the architecture of the ESP32.

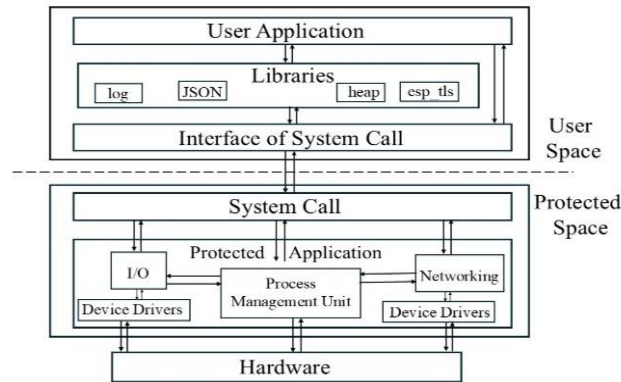

Figure 2 Architecture of the ESP32. Source: Espressif Systems. (n.d.).

3.1.2. Combustion Accident Warning Node (CAWN)

The Combustion Accident Warning Node (CAWN) is designed to minimize fire-related hazards through a two-phase operation: detection and alert. In the first phase, the system detects fire and gas presence. In the second phase, it activates the warning mechanisms. The sensor node relays detection data to the controller, which then initiates the alert protocol.

Fire Detection: CAWN employs infrared (IR) sensing technology to detect fire, leveraging the fact that flames emit radiation primarily in the 700–1100 nm wavelength range. The radiation intensity at a given temperature T is described by Planck’s Law:

$$I(\lambda, T) = \frac{2hc^2}{\lambda^5} \cdot \frac{1}{e^{\frac{hc}{\lambda k_B T}} - 1} \tag{1}$$

A photodiode is used to sense this IR radiation, generating a photocurrent proportional to the incident power:

$$I_{photo} = R_{photo} \cdot P_{incident} \tag{2}$$

Here, $P_{incident}$ denotes the received IR power, and R_{photo} is the photodiode’s responsivity. To enhance detection precision, an optical filter removes visible light, and a bandpass filter isolates flame-specific flickering in the 1–10 Hz range, modeled as:

$$S(t) = S_0 \cdot \sin(2\pi ft) \tag{3}$$

Where f is the flickering frequency, the weak signal is amplified ($V_{out} = G \cdot I_{photo}$), and a comparator determines if $V_{out} > V_{threshold}$ a HIGH signal is outputting if a flame is detected (Arias et al., 2008). (Figure 3) presents the structure diagram of the IR fire detector.

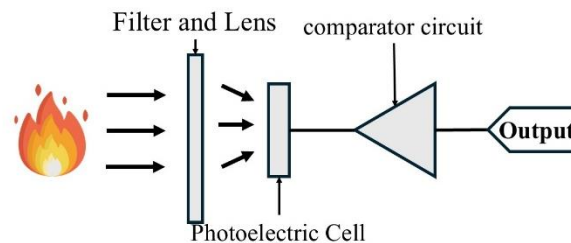

Figure 3 Structure diagram of IR Flame Detector.

Gas Detection: CAWN utilizes metal oxide semiconductor (MOS) gas sensors, which detect gas presence through changes in electrical resistance due to gas adsorption. The sensor comprises a metal oxide sensing layer (e.g., SnO₂), a heater, and two electrodes. Exposure to target gases initiates surface reactions that modify the sensor’s conductivity, which is then processed by the controller. In clean air, oxygen molecules adsorb onto the SnO₂ surface and increase the resistance by capturing free electrons:



When a reducing gas like methane interacts with SnO₂, the gas donates electrons back, reducing resistance:



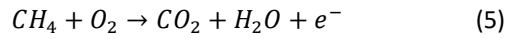

The detector resistance R_s in the presence of gas equation follows:

$$R_s = A \cdot C^B \tag{6}$$

Where A and B are presenting gas-specific constants and C is presenting the gas concentration.

The voltage divider determines the resistance:

$$R_s = R_L \times \left(\frac{V_{cc} - V_{out}}{V_{out}} \right) \tag{7}$$

To determine gas concentration, the sensor is calibrated in clean air (R_0), and the concentration is given by:

$$C = 10^{\left(\frac{\log(R_s / R_0) - \log A}{B} \right)} \tag{8}$$

Equation 8 enables the detection and quantification of gases based on changes in resistance (Dorcea et al., 2018). (Figure 4) presents the structure diagram of a gas detector.

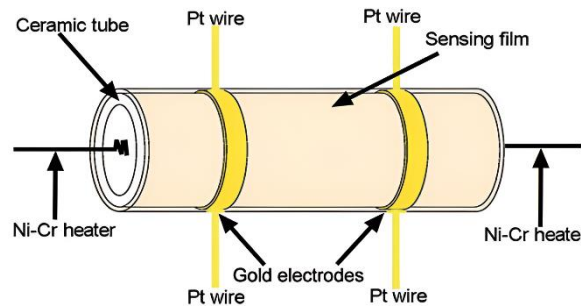

Figure 4 Structure diagram of Gas Detector.
Source: Zhang et al. (2017).

Warning system: The warning mechanism in CAWN employs a magnetic buzzer to emit an audible alert. When an electrical current passes through the buzzer’s coil, it generates a magnetic field that causes a ferromagnetic diaphragm to vibrate. This oscillation produces sound, functioning similarly to a speaker.

The buzzer’s operation is governed by the applied voltage and the coil’s impedance, which together determine the current and, consequently, the sound intensity. This straightforward yet effective system ensures prompt audible notification in the event of fire or gas detection. (Figure 5) Illustrates the internal construction of a magnetic buzzer.

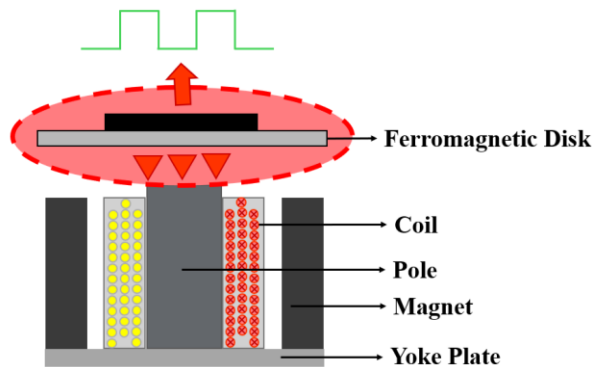

Figure 5 Construction of Magnetic Buzzer.
Source: Hassan & El-Nekhily (2022).

3.1.3. Weather Sensing & Regulation Node (WSRN)

The Weather Sensing and Regulation Node (WSRN) is designed to monitor and regulate ambient temperature and humidity. It operates using a Temperature and Humidity (T&H) sensor, a controller, and an actuator device, such as a fan, for environmental control.

The T&H sensor performs three primary functions: temperature measurement, humidity measurement, and data processing/communication. After collecting environmental data, the sensor transmits it to the controller. Based on predefined logic, the controller analyzes the input and activates the temperature-humidity control device accordingly. This closed-loop system ensures automated climate regulation in response to environmental fluctuations. (Figure 6) displays the T&H sensor component setup.

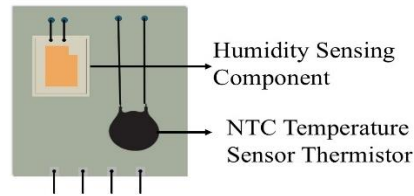

Figure 6 Component setup of (T&H) Sensors.

Temperature and Humidity (T&H) Sensor: The Temperature and Humidity (T&H) sensor utilizes an NTC (Negative Temperature Coefficient) thermistor to measure temperature, where resistance changes with temperature variations. The relationship between temperature and resistance is given by the Steinhart-Hart equation:

$$\frac{1}{T} = A + B \ln(R) + C(\ln(R))^3 \quad (9)$$

Where A, B, and C are Steinhart-Hart coefficients, R is the thermistor resistance, and T is the temperature in Kelvin.

Humidity measurement is achieved by a moisture sensitive capacitor, where capacitance changes depending on humidity variation. (Liu et al., 2017) The capacitance is given by:

$$C = \epsilon_r \epsilon_0 \frac{A}{d} \quad (10)$$

Where ϵ_0 is the permittivity of free space, ϵ_r is relative permittivity, A is the electrode area, and d is the distance between electrodes. Relative Humidity (RH%) is calculated using:

$$RH = \frac{C_{measured} - C_{dry}}{C_{wet} - C_{dry}} \times 100 \quad (11)$$

The sensor transmits (Adafruit Industries, n.d.) data digitally to a microcontroller via a one-wire protocol, sending a 40-bit data packet containing humidity, temperature, and an 8-bit checksum for error detection:

$$Checksum = (Humidity\ High + Humidity\ Low + Temperature\ High + Temperature\ Low) \bmod 256 \quad (12)$$

If the received checksum is incorrect, the data is discarded, ensuring reliability in environmental monitoring applications.

3.1.4. Remote Domestic Appliances Operation Node (RDAON)

The Remote Domestic Appliances Operation Node (RDAON) is designed to enable remote control of household appliances such as televisions, air conditioners, fans, and water pumps. It supports both remote operation via smart devices (e.g., smartphones, laptops) and manual control options. Appliance switching is facilitated through relays, which play a central role in the system's functionality.

Relay: A relay is an electromechanical switch that allows a low-power control signal to operate high-power electrical devices safely. It consists of an electromagnetic coil, armature, spring, and contacts, namely, Normally Open (NO), Normally Closed (NC), and Common (COM). When the coil is energized by a low-voltage signal, it generates a magnetic field that moves the armature, closing the NO contact and opening the NC contact. This action completes the circuit and allows current to flow to the load. When the control signal is removed, the spring returns the armature to its default position, opening the circuit. Relays provide electrical isolation between control and load circuits, ensuring safe and efficient switching. (Figure 7) displays the Circuit Diagram of the Relay.

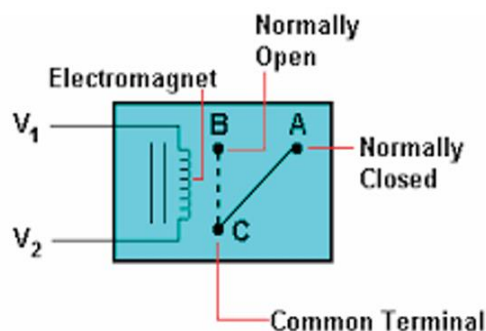

Figure 7 Circuit Diagram of Relay.

Source: Singh & Ansari (2019).

3.1.5. Automate Light Control Node (ALCN)

The Automate Light Control Node (ALCN) regulates lighting based on ambient light levels and supports both manual and remote operation via smartphones or laptops. It uses a Light Dependent Resistor (LDR) to detect the surrounding light intensity. This data is transmitted to a controller, which ascertains the lighting state. If adequate daylight is present, the controller deactivates the light through a relay. Otherwise, it activates the light.

Light Dependent Resistor (LDR): The Light Dependent Resistor (LDR) operates based on the principle of photoconductivity, wherein its resistance varies with incident light intensity. In brighter conditions, the LDR's resistance decreases, resulting in a lower voltage drop across it in a voltage divider circuit. Conversely, in low-light or dark environments, its resistance increases, producing a higher output voltage. This variable voltage signal can be further processed using comparators or analog-to-digital converters (ADCs) for light-level detection and decision-making within the system. (Figure 8) illustrates the structural diagram of an LDR-based detection circuit (Putri & Aryza, 2018).

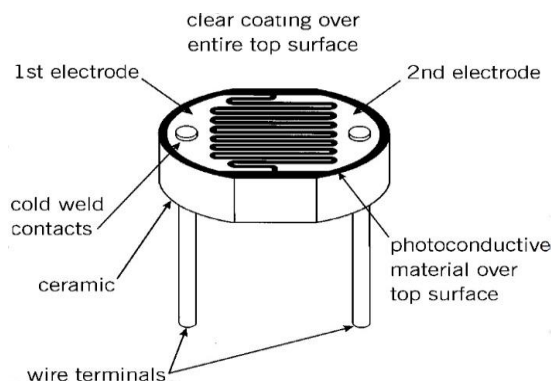

Figure 8 Light Dependent Resistor.
 Source: Echeweozo et al. (2019).

Relay: Section D.1 provided an overview of the fundamental operating mechanism of the relay.

3.1.6. Home Defense Node (HDN)

The Home Defense Node (HDN) is an intruder detection system utilizing a laser beam to monitor a designated area. When an unauthorized object or person interrupts the beam, the system detects the disruption and triggers a warning system. The system is formed by a laser emitter, a warning system, and a Light Dependent Resistor (LDR). The LDR detects the laser beam, and a controller activates the warning system upon detecting an interruption.

Laser Emission: A laser (Light Amplification by Stimulated Emission of Radiation) produces a highly focused light beam used in various technological applications. The laser system includes a ruby crystal inside a flash tube powered by a high-voltage source. When energized, photons excite the crystal's atoms, elevating their electrons to a higher energy state. These electrons eventually return to their ground state and emit photons in the process. This activity is known as spontaneous emission. By stimulated emission, additional photons are generated, which leads to light amplification. The emitted photons form a concentrated laser beam. (Figure 9) illustrates the structure diagram of a laser.

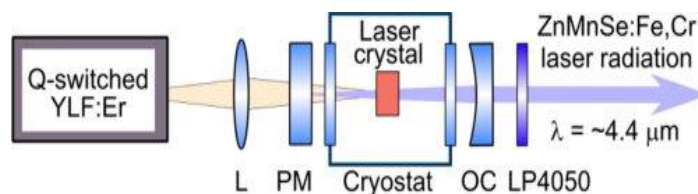

Figure 9 Laser Schematic Diagram.
 Source: Doroshenko et al. (2019).

Light Dependent Resistor (LDR): Sub-section 3.1.5 provide the operational principle of the Light Dependent Resistor (LDR).

Warning System: The previous sub-section 3.1.2 discusses the operational mechanism of the warning system.

3.2. Software Architecture

The software architecture of the Home Automation System is based on the Blynk IoT platform, which facilitates seamless communication between hardware and user interfaces through a cloud-based infrastructure. Blynk enables real-time monitoring and control of microcontrollers such as ESP8266, ESP32, Arduino, and Raspberry Pi. It follows a three-tier

architecture comprising a device layer, a cloud layer, and an application layer, ensuring efficient data exchange and system management (Kulkarni et al., 2021).

Blynk’s graphical user interface (GUI) allows users to create customized dashboards using virtual pins, simplifying sensor data visualization and actuator control without complex programming. The platform supports communication through protocols like MQTT, HTTP, and WebSockets, ensuring reliable connectivity. With automation features, cloud storage integration, and security mechanisms, Blynk is a robust solution for IoT-based home automation systems (Artiyasa et al., 2020). (Figure 10) presents the software architecture block diagram of home automation system.

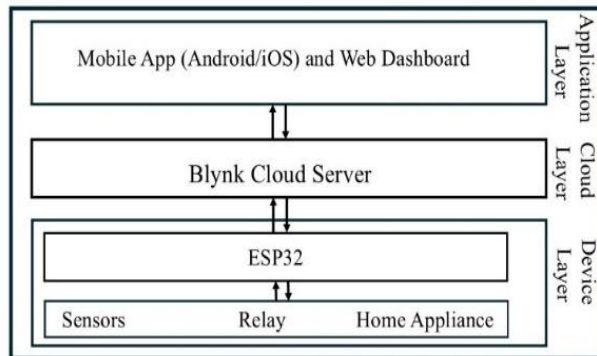

Figure 10 Software Architecture Block Diagram of Home Automation System.

4. Implementation

The description of the implementation of this home automation system is divided into two sections. These two sections are 4.1 Hardware Implementation and 4.2 Software Implementation.

4.1. Hardware Implementation

According to the home automation system architecture consists of a control unit and 5 nodes. Every node is connected to the control unit. Below, describe every node implementation and the connection with the control unit. (Figure 11) presents circuit diagram of the home automation system.

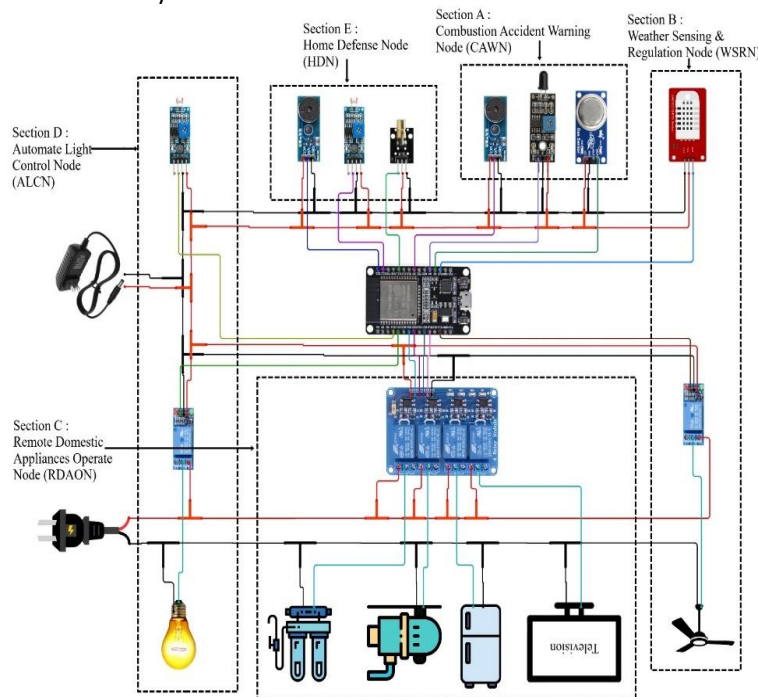

Figure 11 Circuit Diagram of Home Automation System.

4.1.1. Combustion Accident Warning Node (CAWN)

This home automation system employs the CAWN technology to detect fire, gas, or smoke, subsequently sending alert messages and activating a warning system. The CAWN comprises an infrared (IR) fire sensor, an MQ2 smoke sensor, and a

buzzer. These components are connected to the ESP32 microcontroller via pins 4, 2, and 5, respectively. (Figure 11, section A), illustrates the circuit diagram of the CAWN system.

4.1.2. Weather Sensing & Regulation Node (WSRN)

The WSRN technology is used in this system to measure the weather, control the room weather, and monitor the room weather. This node measures the weather and sends this data microcontroller then the microcontroller sends the data user device via a server. This node consists of a DHT22 Temperature and Humidity sensor and a temperature controller-like fan. The DHT22 data pin is connected via 15 number ESP32 microcontroller pin. Relay is used to connect the fan to the microcontroller. The relay is connected to pin 13 of the microcontroller. (Figure 11, section B), presents the circuit diagram of the WSRN system.

4.1.3. Remote Domestic Appliances Operate Node (RDAON)

Home automation system RDAON technology has been implemented to control any home appliance from anywhere in the world using the internet. A relay is used to control every home appliance. Relays are connected to the microcontroller. The reason for using relays is to control high-power circuits with low-power signals. This home automation prototype system is shown controlling 4 home appliances. They are a water pump, water filter, television, and refrigerator. These appliances are connected to the ESP32 microcontroller via relay. The relay is connected to pins 25, 33, 14, and 27, respectively, for every appliance. (Figure 11, section C), presents the circuit diagram of the RDAON system. More home appliances can be added in the same way.

4.1.4. Automate Light Control Node (ALCN)

This home automation system utilizes ALCN technology to regulate lighting based on daylight and remote input. This node comprises a Light Dependent Resistor (LDR) and a relay. These components are interfaced with the ESP32 microcontroller through pins 34 and 35, respectively. The relay is connected to the lighting mechanism. (Figure 11, section D), illustrates the circuit diagram of the WSRN system.

4.1.5. Home Defense Node (HDN)

The HDN technology in this system ensures secure home access by preventing unauthorized entry. This setup includes a laser, an LDR, and a buzzer. The laser, buzzer, and LDR are connected to pins 21, 23, and 22 of the ESP32, respectively. (Figure 14, section E), presents the circuit diagram of the HDN system.

4.2. Software Implementation

A smart central controller based on ESP32 microcontroller is the key component of the Smart Home System. It helps set up and manage a remote monitoring system with control nodes. To manage and control the system requires software. The software for the proposed Smart Home System consists of two parts: Application Software and System software of Microcontroller. (Figure 12) presents the flowchart of the proposed Smart Home System's Software.

4.2.1. Application Software

This online application, built using Blynk, serves as the central hub for managing and maintaining the entire home automation system. It allows users to easily control and monitor various smart devices from anywhere using their smartphone or computer. Blynk ensures smooth communication between smart devices and the app, providing real-time updates and instant control. Whether you're at home or miles away, you'll always have complete access to your automation system. Overall, this application brings convenience, security, and energy efficiency.

4.2.2. System software of Microcontroller

The control unit of the microcontroller operates using software programmed in the C language through the Arduino Integrated Development Environment (IDE). This software serves as the core of the system, enabling communication between the microcontroller and various connected components. By leveraging the capabilities of the Arduino IDE, developers can write, compile, and upload code efficiently, ensuring the smooth operation of the microcontroller. Development Environment (IDE). This software collects data from sensors and processes commands.

5. Results and Discussion

This section provides the experimental evaluation of the proposed IoT-based smart home automation system, analyzing its performance in three crucial areas: network responsiveness for remote commands, intrusion detection accuracy and energy efficiency improvements. The experiments were conducted under various environmental conditions to assess the system's reliability, accuracy, dependability and overall effectiveness. Data collection involved real-time system performance

monitoring, followed by an in-depth analysis of key parameters. The results demonstrate the system’s strengths, providing insights into its practical applicability in modern smart home environments. (Figure 13) presents the proposed system implementation.

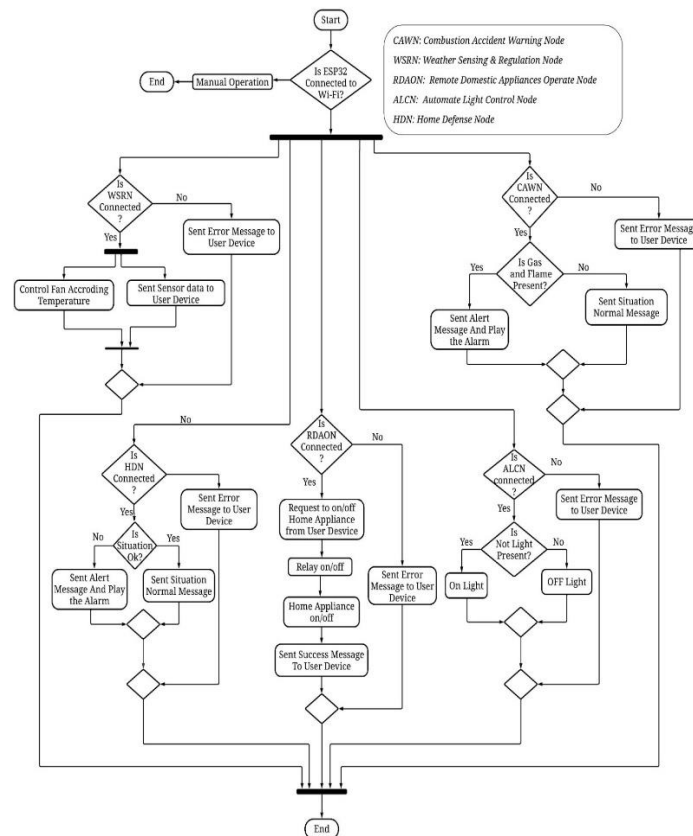

Figure 12 Software working flow chart.

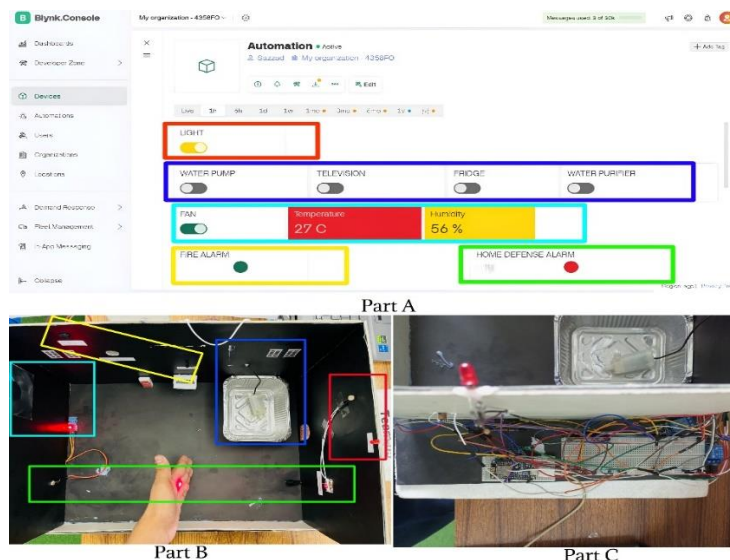

Figure 13 Part A Presents the Software, Part B presents the hardware section and Part C presents the circuit and the control unit. In Parts A and B, the red, blue, cyan, yellow, and green blocks represent the following components, respectively: Light Dependent Resistor (LDR), Remote Domestic Appliances Operate Node (RDAON), Weather Sensing & Regulation Node (WSRN), Combustion Accident Warning Node (CAWN), and Home Defense Node (HDN).

In Part B, the HDN detects unauthorized objects, which is indicated in the software by displaying a red alarm. The WSRN measures temperature and humidity, and this data is also shown in the software. Additionally, the WSRN regulates the fan speed based on the weather conditions.

5.1. System Responsiveness in Remote Home Automation

To evaluate the system's responsiveness, command execution times were measured across different network conditions. The network conditions ranged from low-speed (1 Mbps) to high-speed (20 Mbps) connections. The system was tested by sending 100 remote commands (e.g., turning appliances on/off, changing temperature settings) and recording the average execution time. A Wi-Fi-enabled ESP32 microcontroller was used to relay commands via the Blynk IoT platform, ensuring real-time communication.

The results indicate that the system experienced notable execution delays (1100–1500 ms) under low network speeds (1–5 Mbps), primarily due to increased latency in cloud communication. However, at higher speeds (10–20 Mbps), execution time was significantly reduced to 350–800 ms, indicating near real-time responsiveness. These findings suggest that to maintain optimal system performance, a minimum network speed of 10 Mbps is recommended for smooth operation. (Figure 14) presents a bar chart of this experimental result.

Comparable experiments were conducted by (Haroon et al., 2024) in India and (Pramana et al., 2025) in Indonesia. Their respective systems demonstrated average execution times of 500 ms and 73.4 ms. However, their studies did not report the bandwidth used during testing, which limits the direct comparability of their findings. Notably, both India and Indonesia rank ahead of Bangladesh in mobile network performance, including 5G accessibility and average internet speed (Speedtest, n.d.). These infrastructural advantages likely contributed to their superior execution times.

In the present study, achieving a best-case response time of 350 ms using a 4G network and a 20 Mbps connection in Bangladesh demonstrates the efficiency of the proposed system under relatively constrained network conditions. Furthermore, as 10 Mbps internet speed is widely accessible in Bangladesh, the system's practical applicability and scalability for local deployment are promising.

These findings not only validate the system's real-time capabilities under various bandwidth scenarios but also contribute to the broader literature on IoT-based home automation by demonstrating performance under infrastructurally modest conditions.

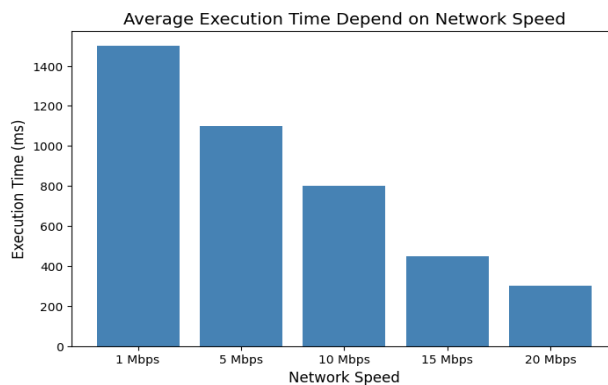

Figure 14 Average Execution Time Depend on Network Speed.

In this figure, the x-axis displays the network speed in Mbps and the y-axis presents the execution time in ms

5.2. Intrusion Detection Accuracy and Response Time

The Home Defense Node (HDN) was evaluated through various simulated intrusion scenarios to assess its detection accuracy and response latency. The system employed a laser-based perimeter detection mechanism utilizing reflectors and Light Dependent Resistors (LDRs). Experimental conditions included fast- and slow-moving objects in both day and night settings, as well as adverse weather conditions such as fog and rain. The HDN consistently achieved over 90% detection accuracy, with response times ranging between 100–300 ms. Performance remained optimal in well-lit and clear environments; however, degradation was observed under low-visibility conditions due to light scattering, particularly in fog or heavy rainfall. Minor false positives occurred when small obstructions like insects or falling leaves disrupted the laser beam, suggesting a need for enhanced filtering algorithms or adaptive calibration.

Compared to existing systems, HDN demonstrated superior performance. For instance, (Insaan et al., 2024) reported a basic Arduino-based laser-LDR system that exhibited poor reliability in low-light environments and a high false-positive rate. (Santhanalakshmi et al., 2024) proposed a laser-photodiode setup that offered scalability but lacked quantitative metrics. Similarly, (Gupta et al., 2023) developed an IoT-based laser alarm with Telegram alerts but did not present detailed performance data. The HDN not only offers empirical validation of detection accuracy and latency but also maintains robustness across variable conditions.

Furthermore, when compared to (Nguyen et al., 2018) DiIoT system—an advanced anomaly detection ML model achieving 95.6% accuracy and 257 ms latency—the HDN delivers comparable performance using simpler, cost-effective

hardware. Unlike D²IoT, HDN was tested in harsh weather conditions, highlighting its practical viability for real-world smart home deployments.

(Figure 15) presents the line chart of this experimental result. In this figure, the x-axis represents the intrusion condition, while the left-side y-axis displays detection accuracy (in percentage), and the right-side y-axis displays response time (in milliseconds).

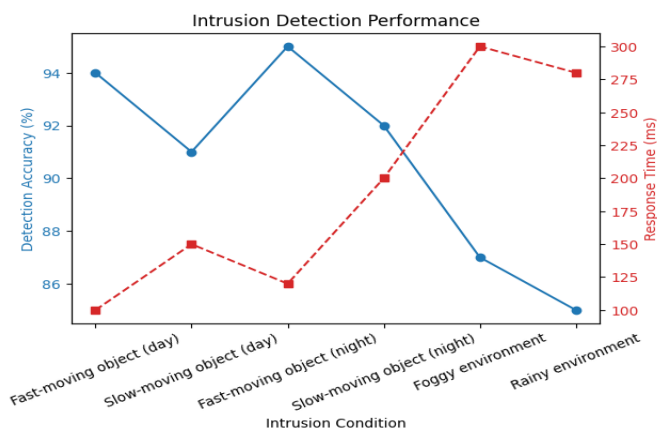

Figure 15 Intrusion Detection Performance.

5.3. Energy Efficiency Comparison with Traditional Systems

To analyze the energy efficiency of the proposed system, power consumption data were collected over one month. Three configurations were compared :

1. Manual Control System – Appliances operated using physical switches.
2. Timer-Based Automation – Devices were controlled based on pre-defined schedules.
3. Proposed IoT-Based System – Appliances were controlled using real-time data from sensors to optimize power usage dynamically.

Below (Table 1) presents a comparison of the proposed IoT-based system with the manual control system and the timer-based system.

Table 1 Comparison between our proposed system energy efficiency vs other existing system.

Parameter	Manual System (Switches Only)	Timer-Based Automation	Proposed IoT-Based System
Avg. Daily Power Consumption (kWh)	9.5 kWh	8.1 kWh	6.3 kWh
Total Monthly Power Consumption (kWh)	285 kWh	243 kWh	189 kWh
Energy Savings vs. Manual	N/A	14.7%	33.7%
Energy Savings vs. Timer-Based	N/A	N/A	22.2%
Estimated Monthly Cost (USD)	18.73 USD	15.97 USD	12.41 USD
Monthly Cost Savings (USD)	N/A	2.76 USD	6.31 USD

The experiment monitored the daily and monthly power consumption of essential household appliances in the context of Bangladesh. It included lights, air conditioners, refrigerators, fans and water pumps. The IoT-based system reduced power use by 33.7% compared to manual control. Additionally, compared to timer-based automation, it saved 22.2% more power. This reduction translated into a significant cost saving, with an estimated monthly electricity bill decrease of 768 BDT (approx. 6.28 USD).

Compared to existing systems, the proposed solution demonstrated superior performance. For instance, (Ahmed and Arafat, 2020) implemented an IoT-based energy-saving strategy in a student residence at the University of Chittagong, achieving a 24% reduction in energy consumption. While substantial, this value falls short of the 33.7% achieved by the proposed system, indicating greater efficiency through real-time dynamic control.

In another study, (Hossain et al., 2022) developed a smart home automation system integrated with renewable energy sources. Although the system aimed to reduce electricity wastage, it did not provide specific quantitative metrics on energy savings, limiting the scope of direct comparison.

Similarly, (Rahman et al., 2025) introduced a predictive IoT framework to estimate energy consumption in households. While the system was technologically promising, the study did not present measured reductions in energy usage, making it less empirically comparable to the current work.

The advanced performance of the proposed system can be attributed to its dynamic optimization approach. Unlike timer-based systems, which operate on rigid schedules, or manual systems that rely on user input, the proposed IoT-based



system responds in real time to occupancy, environmental conditions, and usage patterns. This ensures that appliances operate only when necessary, maximizing energy efficiency.

6. Conclusions

This paper presented an IoT-based smart home automation system that enhances security, energy efficiency, and remote accessibility through a network of sensor nodes and a central control unit. The system integrates fire and gas hazard detection, climate control and remote appliance management. It also has smart lighting and intrusion detection. This system provides a comprehensive solution for modern smart homes. It uses Wi-Fi and Bluetooth for communication. The Blynk IoT platform allows real-time monitoring and control.

Experimental results confirm the system's efficacy. Demonstrating a 33.7% reduction in energy consumption compared to manual control and a 22.2% improvement over timer-based automation, leading to significant cost savings. The Home Defense Node (HDN) achieved over 90% accuracy in intrusion detection with response times between 100–300 ms ensuring robust home security. Furthermore, system responsiveness was optimized for network speeds exceeding 10 Mbps achieving near-instant command execution.

Generally, the proposed system provides a cost-effective, scalable and energy-efficient smart home solution. Future enhancements may include AI-driven automation for adaptive learning and enhanced environmental filtering for intrusion detection. With edge computing integration, local processing can be improved. The findings indicate the potential of IoT in revolutionizing home automation. It increases the usability and accessibility of smart homes.

Ethical considerations

Not applicable.

Conflict of Interest

The authors declare no conflicts of interest.

Funding

This research did not receive any financial support.

References

- Adafruit Industries. (n.d.). Digital humidity and temperature sensor AM2302. *Adafruit Documentation*. Available at: <https://cdn-shop.adafruit.com/datasheets/Digital+humidity+and+temperature+sensor+AM2302.pdf>. Accessed on March 24, 2025.
- Adi Pramana, I. G. B., Akbar, L. A. S. I., & Ramadhani, C. (2025). Development of an IoT-Based Smart Home Prototype Using the Blynk Application. *MOTIVECTION: Journal of Mechanical, Electrical and Industrial Engineering*, 7(1), 25–36. <https://doi.org/10.46574/motivection.v7i1.424>
- Ahmed, M., & Arafat, M. Y. (2020). IoT Based Smart Energy Saving System in Student Hall of University of Chittagong. *International Journal of Computer Applications*, 177(46), 1–5. <https://www.ijcaonline.org/archives/volume177/number46/31220-2020919986>
- Annuar, K. A. M., Maharam, M. F., Ab Hadi, N. A., Harun, M. H., & Ab Halim, M. F. M. (2019). Development of wireless and intelligent home automation system. *TELKOMNIKA (Telecommunication Computing Electronics and Control)*, 17(1), 32-38.
- Arias, L., Torres, S., Sbarbaro, D., & Farias, O. (2008). Photodiode-based sensor for flame sensing and combustion-process monitoring. *Applied Optics*, 47(29), 5541-5549.
- Artiyasa, M., Kusumah, I. H., Suryana, A., Sidik, A. D. W. M., & Junfithrana, A. P. (2020). Comparative study of Internet of Things (IoT) platform for smart home lighting control using NodeMCU with Thingspeak and Blynk web applications. *FIDELITY: Jurnal Teknik Elektro*, 2(1), 1-6.
- Asadullah, M., & Ullah, K. (2017). *Smart home automation system using Bluetooth technology*. In *Proceedings of the 2017 International Conference on Innovations in Electrical Engineering and Computational Technologies (ICIEECT)* (pp. 1-6). Karachi, Pakistan. <https://doi.org/10.1109/ICIEECT.2017.7916544>
- Asha, M. L. A., Rafi, M. A., Ahamed, M. S., & Imran, M. H. (2024, March). Suggesting Playlist and Playing Preferred Music Based on Emotion from Facial Expression. In *2024 3rd International Conference for Innovation in Technology (INOCON)* (pp. 1-5). IEEE.
- Atzori, L., Iera, A., & Morabito, G. (2010). The internet of things: A survey. *Computer Networks*, 54(15), 2787-2805.
- Babiuch, M., Foltýnek, P., & Smutný, P. (2019, May). Using the ESP32 microcontroller for data processing. In *2019 20th International Carpathian Control Conference (ICCC)* (pp. 1-6). IEEE.
- Danbatta, S. J., & Varol, A. (2019, June). Comparison of Zigbee, Z-Wave, Wi-Fi, and Bluetooth wireless technologies used in home automation. In *2019 7th International Symposium on Digital Forensics and Security (ISDFS)* (pp. 1-5). IEEE.
- Dorcea, D., Hnatiuc, M., & Lazar, I. (2018, October). Acquisition and calibration interface for gas sensors. In *2018 IEEE 24th International Symposium for Design and Technology in Electronic Packaging (SIITME)* (pp. 120-123). IEEE.
- Doroshenko, M., Jelínková, H., Říha, A., Jelinek, M., Nemeč, M., Kovalenko, N., & Andrey, S. (2019). Mid-IR (4.4 μm) Zn_{1-x}Mn_xSe:Cr,Fe (x = 0.3) laser pumped by 1.7 μm laser using Cr-Fe energy transfer. *Optics Letters*, 44(10), 2724-2727. <https://doi.org/10.1364/OL.44.002724>
- Echeweozo, E. O., Okoro, N. O., & Ngele, P. (2019). Design, construction and calibration of automatic street light controller using Light Dependent Resistor (LDR). *Journal of Applied Sciences and Environmental Management*, 23(3), 457-459.
- Espressif Systems. (n.d.). ESP32-C3 privilege separation architecture. *Espressif Documentation*. Available at: <https://docs.espressif.com/projects/esp-privilege-separation/en/latest/esp32c3/technical-details/architecture.html>. Accessed on March 24, 2025.

- Gupta, D., Srivastava, I., Verma, S., Saraswat, G., Mishra, S., & Agarwal, R. (2023). IoT-based laser anti-theft security system with Telegram and Gmail alert. *International Journal of Advanced Research in Science, Communication and Technology*, 3(14), 349–355. <https://ijarsct.co.in/Paper10850.pdf>
- Hafizul Imran, M., Ziaul Haque Zim, M., & Ahmmed, M. (2021). PIRATE: design and implementation of pipe inspection robot. In *Proceedings of International Joint Conference on Advances in Computational Intelligence: IJACI 2020* (pp. 77-88). Springer Singapore.
- Haroon, G. A. L., Fayaz, M., & Baig, M. S. (2024). Home automation using Wi-Fi ESP32-based system for remote control and environmental monitoring. *ResearchGate*. <https://www.researchgate.net/publication/381394710>
- Hassan, Y. T., & El-Nekhily, A. (2022). Guarding system using geophones. *ResearchGate*. Available at: <https://www.researchgate.net/publication/380891062>.
- Hossain, M. A., Hasan, M. M., & Arman, M. M. (2022). Design and Development of IoT Based Smart Home System Using Renewable Energy Source. *American Journal of Applied Sciences and Engineering*, 3(3), 83–93. <https://journals.e-palli.com/home/index.php/ajaset/article/view/820>
- Imran, M. H., Mahi, R. B., Saha, R., Islam, M. H., & Mahmud, I. (2022). NISHASH: A reasonable cost-effective mechanical ventilator for COVID affected patients in Bangladesh. *Heliyon*, 8(5).
- Insaan, N., Maulana, Y., Rengga, N., Junantoro, H., Rifky, R., & Pradana, A. I. (2024). Innovative laser alarm system for enhanced home security and burglary prevention. *IC-ITECHS*, 5(1), 747–752. <https://doi.org/10.32664/ic-itechs.v5i1.1654>
- Katariya, J. K., Manjunath, H. R., Malviya, A., & Kumar, R. (2024). *Securing the IoT wireless communication system: A multi-access physical layer approach*. *Multidisciplinary Science Journal*, 6, 2024ss0320. <https://doi.org/10.31893/multiscience.2024ss0320>
- Kulkarni, H., Joshi, A., Kadam, S., & Jain, R. (2021). IoT-based smart irrigation system. *International Journal of Advanced Research in Electrical, Electronics and Instrumentation Engineering*, 10(6), 1886-1891. <https://doi.org/10.15662/IJAREEIE.2021.1006040>
- Liu, M. Q., Wang, C., & Kim, N. Y. (2017). High-sensitivity and low-hysteresis porous MIM-type capacitive humidity sensor using functional polymer mixed with TiO₂ microparticles. *Sensors*, 17(2), 284.
- Mahi, M. J. N., Chaki, S., Humayun, E., Imran, H., Barros, A., & Whaiduzzaman, M. (2023). A review on VANET security: Future challenges and open issues. *Indonesian Journal of Electrical Engineering and Informatics (IJEEI)*, 11(1), 180-193.
- MarketsandMarkets. (n.d.). *Home automation system market report*. Available at: <https://www.marketsandmarkets.com/Market-Reports/home-automation-control-systems-market-469.html>. Accessed on March 24, 2025.
- Maslan, M. N., Ramli, I. R., Md Fauadi, M. H. F., Ayob, M. E., Baharom, M. F., Ghazali, I., & Tanjung, T. (2025). *Design and implementation of outdoor home smart farming based on Raspberry Pi for home assistant management*. *Multidisciplinary Science Journal*, 7(8), 2025418. <https://doi.org/10.31893/multiscience.2025418>
- Mudgil, S., & Rajoriya, S. R. (2024). Smart home automation using ThingSpeak cloud. *International Journal of Innovative Research in Technology (IJIRT)*, 11(2), 979.
- Muthmainnah, M., Mulyadi, M. F., Tazi, I., Mulyono, A., Hananto, F. S., Chamidah, N., & Kusairi. (2024). *Development of an automated monitoring system for soil moisture and temperature in smart agriculture to enhance lettuce farming productivity based on IoT*. *Multidisciplinary Science Journal*, 6(11), 2024233. <https://doi.org/10.31893/multiscience.2024233>
- Nagayo, A. M., Al Ajmi, M. Z., Guduri, N. R. K., & Al Buradai, F. (2024). *Monitoring stress levels and associated clinical health risks utilizing IoT and AI technologies to promote mental health awareness in educational institutions*. *Multidisciplinary Science Journal*, 6, 2024ss0327. <https://doi.org/10.31893/multiscience.2024ss0327>
- Nguyen, T. D., Marchal, S., Miettinen, M., Fereidooni, H., Asokan, N., & Sadeghi, A.-R. (2018). DfIoT: A federated self-learning anomaly detection system for IoT. *arXiv*. <https://doi.org/10.48550/arXiv.1804.07474>
- Obayuwana, A., Olah, D., & Akinbohun, S. (2024). Enhancing fire safety through IoT-enabled flame detection systems: A cost-effective and scalable approach. *Proceedings of the Nigerian Academy of Science*, 17(1), 54-67.
- Pradhan, S., Nayak, A., & Sharma, G. A. (2021). *Smart lighting system using light dependent resistor (LDR)*. *International Journal of Academic and Applied Research (IJAAAR)*, 5(8), 32-37.
- Putri, M., & Aryza, S. (2018). Design of security tools using sensor Light Dependent Resistor (LDR) through mobile phone. *International Journal of Innovative Research in Computer and Communication Engineering*, 4(10), 168-173.
- Rahman, M. M., Hasan, M. A., & Hossain, M. M. (2025). IoT Based Smart Energy Consumption Prediction for Home Appliances. *ResearchGate*. https://www.researchgate.net/publication/390586807_IoT_Based_Smart_Energy_Consumption_Prediction_for_Home_Appliances
- Saeed, M. Z., Ahmed, R. R., Samin, O. B., & Ali, N. (2019, December). IoT based smart security system using PIR and microwave sensors. In *2019 13th International Conference on Mathematics, Actuarial Science, Computer Science and Statistics (MACS)* (pp. 1-5). IEEE.
- Santhanalakshmi, P., & Alexander, A. (2024). Laser light based security system. *International Journal of Innovative Research in Science, Engineering and Technology (IJIRSET)*, 13(6), Article 76. https://www.ijirset.com/upload/2024/june/76_Laser.pdf
- Singh, H., Pallagani, V., Khandelwal, V., & Venkanna, U. (2018, March). IoT-based smart home automation system using sensor node. In *Proceedings of the 2018 4th International Conference on Recent Advances in Information Technology (RAIT)* (pp. 1-5). IEEE.
- Singh, U., & Ansari, M. A. (2019, October). Smart home automation system using Internet of Things. In *2019 2nd International Conference on Power Energy, Environment and Intelligent Control (PEEIC)* (pp. 144-149). IEEE.
- Speedtest. (n.d.). *Global index: Mobile performance*. Retrieved June 6, 2025, from <https://www.speedtest.net/global-index#mobile>
- Zhang, H., Xu, X., Zhu, Y., Bao, K., Lu, Z., Sun, P., ... & Lu, G. (2017). Synthesis and NO₂ gas-sensing properties of coral-like indium oxide via a facile solvothermal method. *RSC Advances*, 7(78), 49273-49278.