

# Integrating water quality model and aeration with IoT technology in water quality management: A conceptual framework



Mira Mazlina Mahdzir<sup>a</sup> | Saifudin Hafiz Yahaya<sup>a</sup> | Muhammad Hafidz Fazli Md. Fauadi<sup>a</sup> | Tneh Tze Yeow<sup>b</sup>

<sup>a</sup>Fakulti Teknologi dan Kejuruteraan Industri dan Pembuatan, Universiti Teknikal Malaysia Melaka, Durian Tunggal, Melaka, Malaysia.

<sup>b</sup>Toray Malaysia Systems Solution SDN BHD, Bayan Lepas, Pulau Pinang, Malaysia.

**Abstract** Eutrophication poses a significant threat to both human population growth and aquatic life. It gives rise to a range of issues, including algae blooms, loss of habitat, reduced self-purification capacity, and changes in the biodiversity system. In order to restore the ecosystem, it is imperative to implement water quality management measures to combat eutrophication. Common methods for mitigating eutrophication include the use of water quality models, aeration, and IoT technology. Water quality model simulations have been demonstrated to accurately predict future water quality. Aeration, on the other hand, increases oxygen concentration in water through dispersion. Furthermore, the utilization of IoT in water quality monitoring provides users with precise and real-time data. Despite research findings that suggest the effectiveness of water quality models, aeration, and IoT technologies in addressing eutrophication, their current integration is inadequate. Therefore, the aim of this paper is to develop a conceptual framework that incorporates water quality models, aeration, and IoT technology to regulate water quality, with a specific focus on preventing the eutrophication issue. The conceptual framework was created by studying existing research on frameworks for water treatment, water quality modelling, aerators, and IoT technologies. Several adjustments were made to tailor the general framework to the specific requirements of this study. The discussion emphasizes the advantages of conceptual framework development in managing water quality, which integrates water quality models, aerators, and IoT technologies. This framework is expected to serve as an effective tool for managing eutrophication in water, while also promoting sustainable measures to address water contamination.

**Keywords:** aeration, eutrophication, live monitoring, water quality, water quality model

## 1. Introduction

Water is a vital resource for the existence of living organisms on Earth, as well as the primary source for those engaged in farming and other enterprises (Sahaana et al., 2022). According to Sinha et al. (2017), excessive nutrient enrichment, or eutrophication, is a hazard to global water supply. Water resources are increasingly being threatened by water contamination (Pak et al., 2021; Yang et al., 2018). Environmental factors such as salinity, pH, temperature, low wave activity, slow-moving currents, and excessive fertilizer nitrogen intake can all cause eutrophication in water bodies (Suteja & Dirgayusa, 2018). Untreated water bodies can grow aerobic bacteria because of organic pollutants such as protein, carbohydrates, and organic acid. This bacterial growth consumes significant quantities of dissolved oxygen. The dissolved oxygen (DO) concentration decreases when the oxygen acquired from photosynthesis and the atmosphere is insufficient to meet the oxygen use. As the concentration approaches zero, the growth of anaerobic bacteria speeds up, causing a decline in water quality. This leads to the death of aquatic organisms and significant contamination of the water with a strong stench and reduced value (Bai et al., 2018).

Water quality models simulate heat transfer, hydrodynamics, and processes related to water quality in bodies of water to forecast the path and the destiny of contaminants or water quality components. Equations describing significant physical, chemical, and biological processes are solved analytically or numerically using models. The quantities of nutrients, pathogens, microorganisms, and other components in a water body can be replicated using these models (Fan et al., 2009; Jeznach et al., 2016). According to Sharma and Kaushal (2021), physical, chemical, and biological water quality variables must be included as input to a water quality model. Water flows, dissolved oxygen concentrations, pH, temperature, turbidity, dissolved particles, and nutrients are a few factors that are used to evaluate the quality of water (Sharma & Kaushal, 2021). The models of water



quality that are frequently used are AGNPS, BASINS, QUAL, WASP, and SWAT. Every model has a different function and makes use of different simulation techniques (Mulla et al., 2019).

Nevertheless, the water quality model does not help to enhance surface water quality. Enhancing the oxygen concentration is critical for polluted water remediation. The primary objective is to mitigate the rise and emergence of nutrient loading through restoration efforts (Jilbert et al., 2020). As a result, aeration is critical for both wastewater treatment and aquaculture because it improves oxygen delivery. Aeration is crucial for enhancing energy efficiency since biological activities rely on the adequate presence of dissolved oxygen in water (Gu et al., 2023). The inadequate levels of dissolved oxygen (DO) in natural water sources necessitate the use of aeration to ensure water circulation and enhance oxygen supply, particularly in situations of increasing stocking density (Marappan et al., 2020).

At present, the conventional method of measuring water quality parameters is still in use. Unfortunately, this approach requires on-site sample collection, which is expensive and labor-intensive, and then follows with chemical analysis in a lab. The accuracy of measurements may be impacted by reactions between water nutrient concentrations and the surrounding environment during transportation to the lab. Khatri et al. (2019) stated that the implementation of real-time water quality monitoring is essential in order to decrease labour expenses and time consumption. The Internet of Things, or IoT, is a network of physically linked objects, such as mobile phones, cameras, home and automotive electronics, and other gadgets. These things have the ability to communicate and exchange data. The utilisation of diverse sensors, made possible by recent advancements in IoT technology, has streamlined the process of monitoring and assessing water quality, while also diminishing eutrophication (Rostam et al., 2021). Bhardwaj et al. (2022) assert that smart sensor devices enhance both security and efficiency of water management for both workers and customers by collecting real-time data, providing alerts, and facilitating preventive measures. Regular monitoring and sampling should be conducted to collect more information on water quality indicators. Systematic monitoring effectively resolves the problem of frequency by necessitating extended and thorough scrutiny, sampling, and data collection (O'Grady et al., 2021).

Previous research has widely discussed the impact of the water quality model, aeration, and IoT in water quality management. According to previous researchers, water quality models can predict future water quality conditions, which will provide an intensive solution to reduce pollution (Al-Dalimy & Al-Zubaidi, 2023; Iqbal et al., 2018; Munirah et al., 2021; Samaneh Abdeveis et al., 2020; Xiong et al., 2022; Zehra et al., 2023). A lot of research has also been done on IoT live monitoring (Hakimi & Jamil, 2021; Joshi et al., 2020; Pasika & Gandla, 2020; Roshidi & Thirunavakkarasu, 2021; Satra et al., 2024; Sivakumar & Ramya, 2021) and aeration for restoration (Bahri et al., 2019; Jayanthi et al., 2020; Nugroho et al., 2021; Omofunmi et al., 2017; Ridwan et al., 2023; Tanveer et al., 2018). Water quality management has also practically used the combination of aerator and IoT (Juliyanto et al., 2023; Tsai et al., 2022).

Nevertheless, there is a lack of comprehensive research on the integration of these techniques for water quality management (Mahdzir et al., 2024). Srinivas and Singh (2018) recognized the importance of water quality models as a significant tool for policymakers to implement successful action plans. However, Wimordi et al. (2021) emphasised that these models also require other ways of water quality control. Dumlu and Elçi (2022) have shown that the utilisation of a water quality model in combination with an aerator can enhance the level of dissolved oxygen, resulting in improved water conditions. Furthermore, the implementation of IoT technology in the research industry has emerged as the most effective approach for monitoring water quality. Lakshmikantha et al. (2021) suggested employing IoT technology as a surveillance system to check water quality. This system has the ability to accurately assess important quality measurements, rapidly identify warnings, and offer real-time data for taking necessary steps.

Therefore, this paper is intended to propose a conceptual framework that integrates the water quality model, aeration and IoT as a water quality management practice to control the eutrophication of water. A few frameworks will be discussed in this paper which include water treatment, water quality model, aerator design and IoT implementation.

## 2. Methods

This paper aims to develop a conceptual framework for water quality management that integrates a water quality model, aeration and IoT technology. The research methods are delineated in a few procedures:

### 2.1. Problem statement

Water quality management is an effective approach to control water eutrophication. Aeration, IoT technology, and the water quality model are just a few of the approaches to water quality management that have been discussed. It highlighted how those techniques improved the management of water quality. Nevertheless, there is still a lack of study on the combination of IoT technologies, aeration, and water quality models for managing water quality. As a result, this paper will establish a conceptual framework for water quality management practices that include the integration of the water quality model, aeration, and IoT.

### 2.2. Finding relevance framework

This study addressed the lack of specific methodology guidance in the existing literature on water quality management, particularly about aeration, IoT technology, and water quality models. To overcome this gap, the study utilized a general robustness framework developed by Nemani et al. (2023) and incorporated a methodological approach from previous studies. Nemani et al. (2023) suggested using their advanced robustness framework to assess water quality parameters. The framework has six steps, as seen in Figure 1. Step 1 of this framework proposes the selection of water quality parameters that are specifically relevant to the study location. The framework also provides the option to categorize each parameter based on its respective value. In Step 2, it is necessary to assess the status of the study area to determine if any improvements are required or if the opposite is true. During Step 3, the water quality measures are selected based on their appropriateness for the study region. Step 4 will involve an assessment of the approach to addressing water quality metrics. This is to ascertain whether existing methods exist for addressing water quality criteria, or if new methods need to be developed. After acquiring the method, the evaluation of the treatment process for water quality parameters will be interpreted following the study's objectives, as outlined in Step 5. The next phase involves modifying the treatment technique to suit the specific study region. This framework will serve as the basic framework for the technique used in this study.

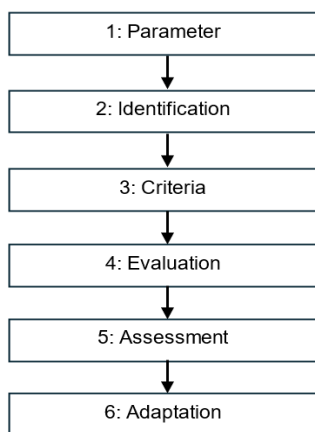

**Figure 1** General robustness framework for water treatment. Source: Nemani et al. (2023).

Furthermore, Jeznach et al. (2016), Daggupati et al. (2015), and Harmel et al. (2014) conducted research that forms the basis for the application of the water quality model. Jeznach et al. (2016) introduced the framework, depicted in Figure 2, for applying a water quality model to analyze contamination in reservoirs and propose remedial strategies. Before implementing the water quality model, it is critical to determine the properties of the water, including its velocity, depth, longitudinal and lateral dimensions, as well as the inflows and outflows. Once the qualities of the water have been identified, the subsequent stage in the approach involves choosing a water quality model and then calibrating it. Jeznach et al. (2016) further said that the process of calibrating and validating the model involves the use of data pertaining to these specific water quality measures. Daggupati et al. (2015) and Harmel et al. (2014) constructed an identical framework for the implementation of water quality models. They underlined the significance of comprehending the model's concept and the important role of the validation process in evaluating the model's accuracy and performance. The next step involves scenario planning after the model has been completed. The water quality model will assess the level of concern at a specific area by analyzing the features of the contaminant in the water. This model will simulate the water's future condition using software input data and existing water quality factors to simulate the future condition of the water.

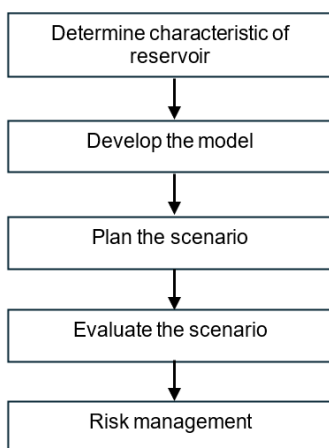

**Figure 2** Framework for evaluating the effects of contaminants on the quality of reservoir water. Source: Jeznach et al. (2016).



Subsequently, Ridwan et al. (2024), Juliyanto et al. (2023), Mubarak et al. (2022), and Hasnol and Zaharuddin (2020) have studied the application of aerator and IoT technology. The studies conducted by Mubarak et al. (2022) and Hasnol and Zaharuddin (2020) highlighted the sequential steps involved in the design of an aerator, encompassing the key components of design, prototyping, experimentation, and analysis. Figure 3 depicts the research model chart used by Mubarak et al. (2022) to design an aerator blade. This study uses Solidwork software to design the aerator blade in both 2D and 3D. Once we completed the aerator design, we generated the file format as an STL file. The 3D software will facilitate the prototyping process by enabling the use of a prototype machine. Prior to establishing the 3D design, Ridwan et al. (2023) determined it was necessary to verify the design's stability using software. After that, experimental testing can be conducted to determine the design's impact on water quality measures. Afterwards, data will be acquired and evaluated.

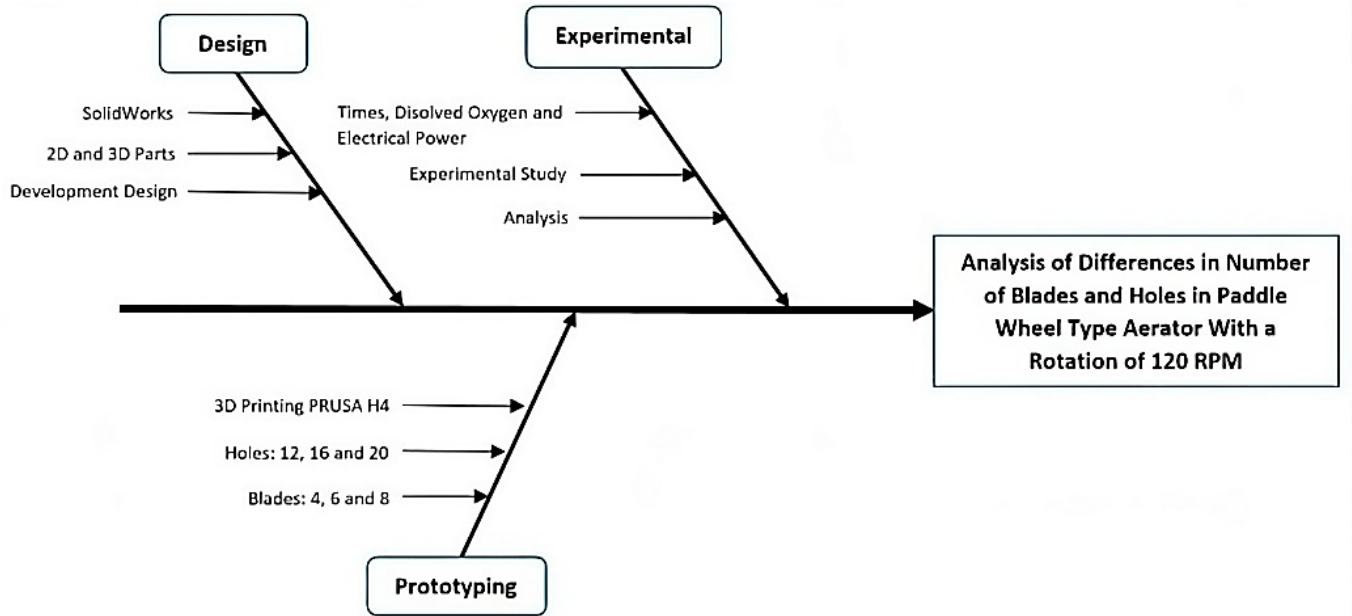

Figure 3 Research model chart to design aerator blade. Source: Mubarak et al. (2022).

Additionally, Ridwan et al. (2024) have continued the investigation by incorporating IoT technology to ensure that the water is in its ideal state and to collect continuous monitoring data. Figure 4 shows the block diagram of the developed tool, illustrating the input, process, and output components of the designed tools. The inputs comprise sensors designed to detect various water quality indicators, while the output involves motors responsible for rotating the blade and screen. However, this investigation employs microcontroller circuits and software to process the input and transmit the data for output. The NodeMCU microcontroller facilitates Wi-Fi connectivity for Internet of Things (IoT) systems and can connect to any device's software. Figure 5 displays an illustrated flowchart system for an aerator equipped with IoT devices.

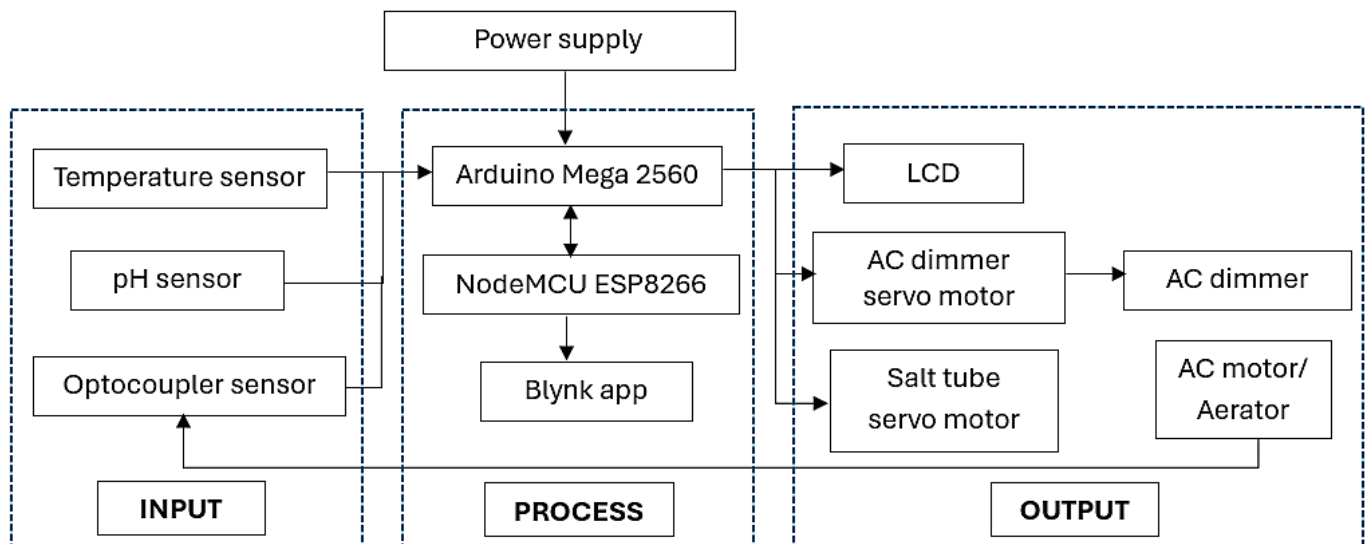

Figure 4 Block diagram of IoT system. Source: Ridwan et al. (2024).

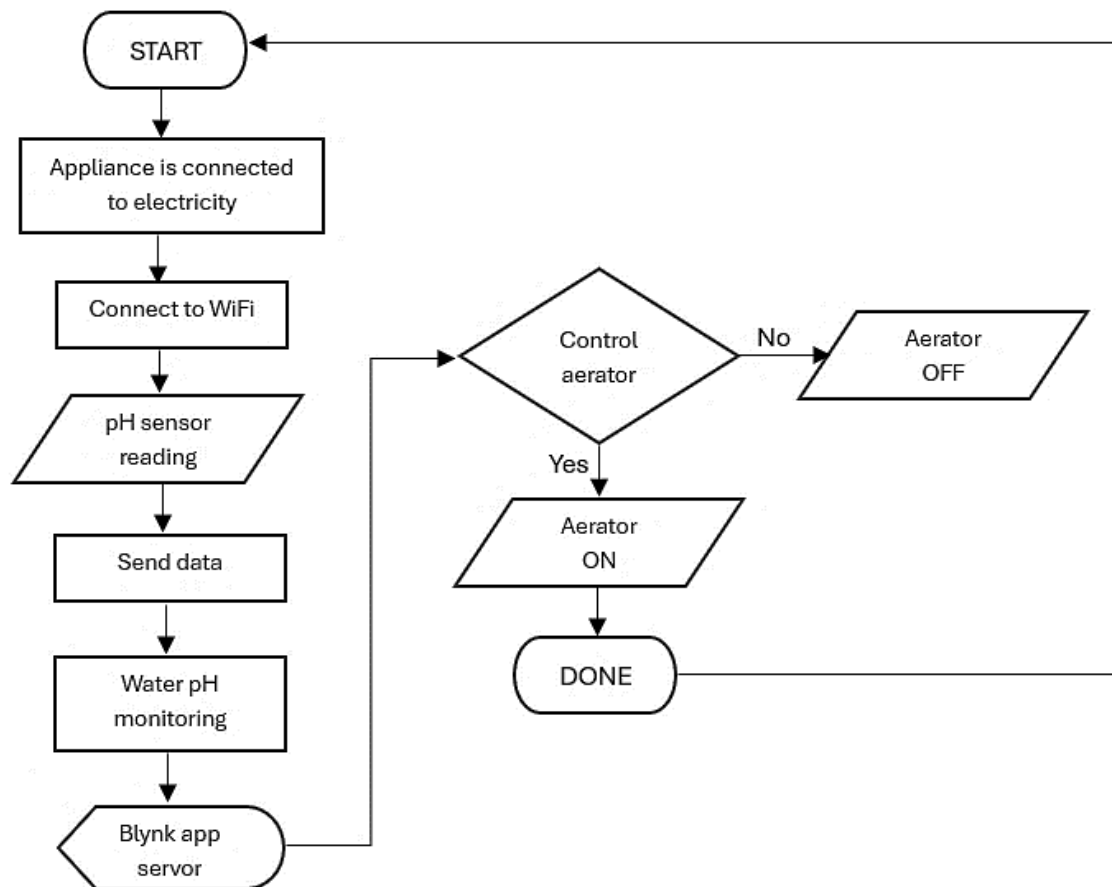

Figure 5 Flowchart of aerator with IoT. Source: Juliyanto et al. (2023).

### 3. The Proposed Framework

As previously mentioned, the management of water quality still lacks a methodology for water quality parameters that incorporates aeration, IoT, and a water quality model. Therefore, this study presented a systematic strategy to develop a conceptual framework consisting of all three of these methodologies. Nemani et al. (2023) developed a comprehensive framework that identifies criteria for water quality metrics before implementing water treatment processes, making it the primary framework for this study. The water treatment procedure can be utilized as a means of managing water quality for this study, as it serves the similar objective of enhancing water quality. However, this framework lacks the inclusion of a methodology that encompasses a water quality model, aeration, and IoT technologies. Dumlu and Elçi (2022) proposed the use of a water quality model and aeration as a way of effectively controlling water in rivers that are contaminated. In addition, Dube et al. (2020), Johan et al. (2021), and Deepika et al. (2019) acknowledged the benefits of IoT technology for real-time monitoring. In particular, Ridwan et al. (2024) have shown that combining IoT technology with an aerator can improve the effectiveness of the aeration system by allowing for immediate monitoring of water conditions. Integrating a water quality model, aeration, and live monitoring will positively improve water quality management. The framework shown in Figure 6 is derived from the general framework established by Nemani et al. (2023), with the integration of several supplementary stages related to the management of water quality as studied in previous research. The framework is subject to several modifications depending on the suitability of the studies. For example, the adapted stage for Step 2 incorporates both Step 2 and Step 3 from the general framework. This combination is done since both of the steps serve the same purpose, which is related to the criteria of the water quality based on the water quality parameter measured. Step 3 integrates the water quality model's evaluation of water quality parameters into the framework, while Step 4 incorporates the aerator and IoT. The order between Step 4 and Step 5 is changed compared to the general framework to achieve the flow of the study

Moreover, Figure 7 presents a detailed framework that outlines the process for each step in the framework presented in Figure 6, while Figure 8 presents a flow chart that illustrates the overall process. This includes the application of the water quality model, aerator, and IoT for water quality management. This framework bases the details of the process on previously discussed studies. In summary, the section outlines the development of a new framework that aims to enhance water quality management by combining water quality modeling, aeration, and IoT technology, reflecting a significant advancement in addressing water contamination issues.



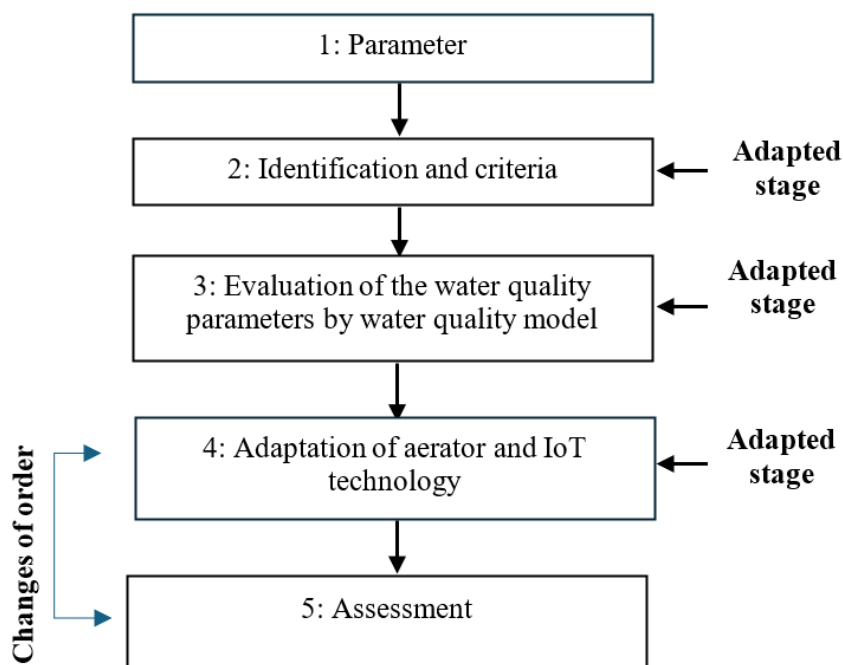

Figure 6 Framework for water quality management that integrate water quality model, aeration and IoT technology.

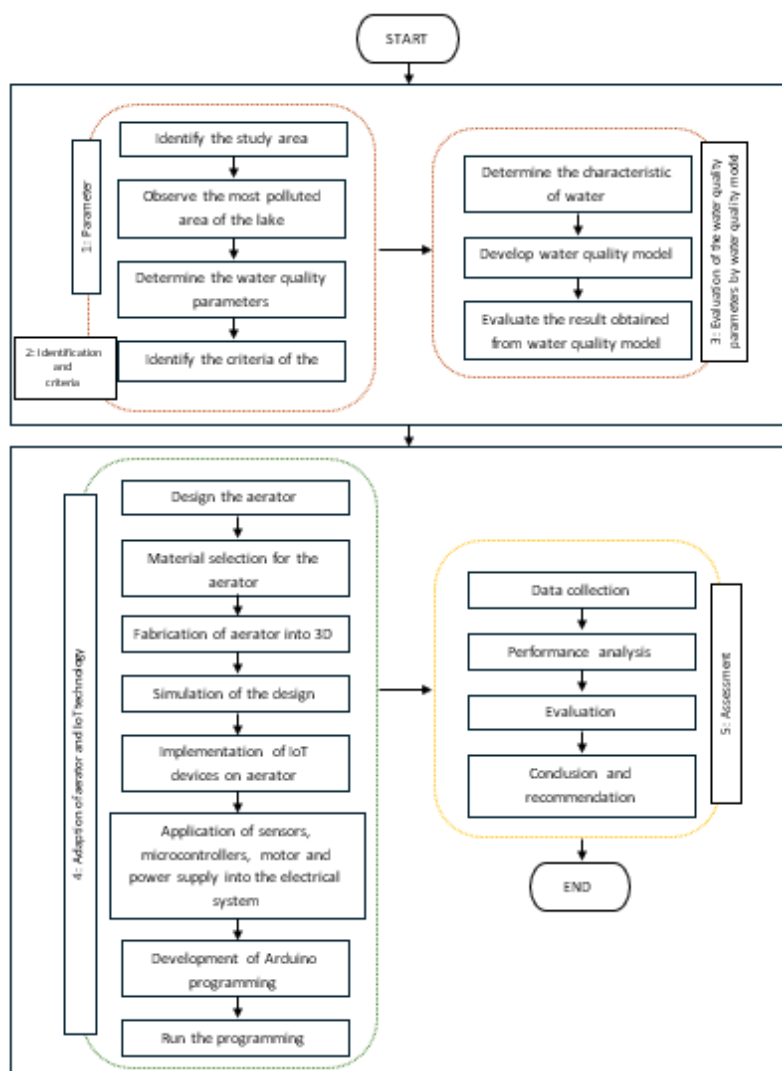

Figure 7 Detailed explanation on the framework.

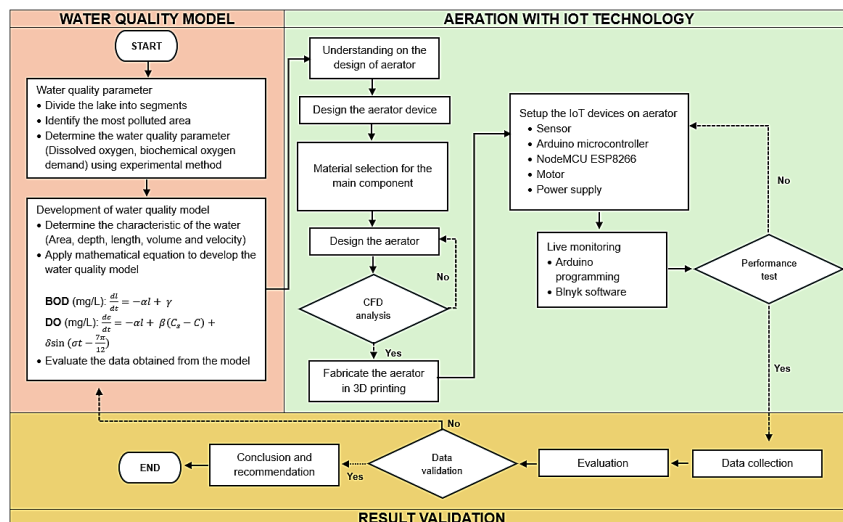

Figure 8 Flow chart based on framework proposed.

4. Discussion

There are many guidelines and methodologies for water quality management systems, and this paper has proposed a conceptual framework that integrates the water quality model, aeration, and IoT technology. It shows that Nemani et al. (2023) general framework can serve as the main framework of the study because it includes the basic process of treating polluted water. However, modifications to the general framework are required in order to incorporate the water quality model, aeration, and IoT technology into the process. As previously discussed, each of the water quality management methods has the potential to improve water quality. Yet, Wimordi et al. (2021) mentioned that the water quality model itself is insufficient for water quality management. Ahmed et al. (2022) have suggested that a hybrid approach in order to achieve an efficient and accurate result to evaluate the water quality parameters.

In addition, Dumlu and Elçi (2022) have implemented the water quality model and aerator as methodologies for improving water quality. The research found that water quality parameters can be simulated to determine which area is the most concerning. As mentioned by Srinivas and Singh (2018), the water quality model is an appropriate tool for remediation action plans. In addition, the water quality model used by Dumlu and Elçi (2022) also observed that with the application of aeration, the water quality has improved. It is proven that the combination of a water quality model and aeration can provide conducive water quality management. Furthermore, Juliyanto et al. (2023) and Tsai et al. (2022) have adapted an aerator with IoT technology to monitor the water quality remotely to achieve accurate and real-time data. Juliyanto et al. (2023) mentioned that with the aerator's oxidation process, the quality of the water can be improved. Besides, the application of IoT to control the aerator and monitor the water quality parameter became an effective way to maintain the water condition. Meanwhile, Tsai et al. (2022) have found that aeration managed to increase the survival rate of the shrimp up to 33.3% by monitoring the water quality parameters and aerator through IoT. A better survival rate of aquaculture can be achieved with an aerator by enhancing the oxygen supply (Tanveer et al., 2018), and real-time analysis of water quality parameters can be obtained by IoT technology (Lakshmikantha et al., 2021).

The discussion reveals that the research gap lies in the integration of water quality models and aeration with IoT features for water quality management. Thus, this study incorporates various methodologies from past research that collaborate with water quality models, aerators, and IoT technology. The study suggests that this framework could be a crucial component of water quality management practices aimed at enhancing the quality of water since each of the methods is proven to be successful in water quality management.

5. Conclusions

Water quality management is an important method for controlling the eutrophication level of water. As a result, the primary contribution of this study is the development of a conceptual framework for water quality management that integrates the water quality model, aeration, and IoT technology. Overall, the framework will offer a comprehensive approach to enhance water quality. The water quality model can predict the condition of the water in the future based on the water quality parameter measured, and the application of an aerator can improve the water quality by increasing the dissolved oxygen. In the meantime, IoT technology offers real-time data, enabling continuous and remote measurements of water quality from any device. Therefore, this paper anticipates that the proposed framework will enhance water quality management, particularly in eutrophic ecosystems. This can be a sustainable practice to overcome polluted water.



## Acknowledgment

The authors would like to express our gratitude and appreciation to the Zamalah Scheme and Fakulti Teknologi dan Kejuruteraan Industri dan Pembuatan, Universiti Teknikal Malaysia Melaka for the support extended in realizing the success and smooth implementation of this project.

## Ethical considerations

Not applicable.

## Conflict of Interest

The article has not been published elsewhere and it is not under consideration by other journals. All authors have approved the review, agree with its submission and declare no conflict of interest in the article.

## Funding

This research is funded by the Zamalah Scheme, Universiti Teknikal Malaysia Melaka.

## References

- Ahmed, M., Mumtaz, R., Anwar, Z., Shaukat, A., Arif, O., & Shafait, F. (2022). A Multi-Step Approach for Optically Active and Inactive Water Quality Parameter Estimation Using Deep Learning and Remote Remote Sensing. *Water*, 14(13), 1–22. <https://doi.org/https://doi.org/10.3390/w14132112>
- Al-Dalimy, S. Z., & Al-Zubaidi, H. A. M. (2023). Application of QUAL2K Model for Simulating Water Quality in Hilla River, Iraq. *Journal of Ecological Engineering*, 24(6), 272–280. <https://doi.org/10.12911/22998993/162873>
- Bahri, S., Jufriadi, & Anwar, H. (2019). The Ineffectiveness of Water Splash on Paddlewheel Aerator. *IOP Conference Series: Earth and Environmental Science* (p. 268). Kuala Lumpur, MY. <https://doi.org/10.1088/1755-1315/268/1/012162>
- Bai, S., Wang, X., Zhao, X., & Ren, N. (2018). Characterizing water pollution potential in life cycle impact assessment based on bacterial growth and water quality models. *Water (Switzerland)*, 10(11), 1–14. <https://doi.org/10.3390/w10111621>
- Bhardwaj, A., Dagar, V., Khan, M. O., Aggarwal, A., Alvarado, R., Kumar, M., Irfan, M., & Proshad, R. (2022). Smart IoT and Machine Learning-based Framework for Water Quality Assessment and Device Component Monitoring. *Environmental Science and Pollution Research*, 29(30), 46018–46036. <https://doi.org/10.1007/s11356-022-19014-3>
- Daggupati, P., Pai, N., Ale, S., Douglas-Mankin, K. R., Zeckoski, R. W., Jeong, J., Parajuli, P. B., Saraswat, D., & Youssef, M. A. (2015). A recommended calibration and validation strategy for hydrologic and water quality models. *Transactions of the ASABE*, 58(6), 1705–1719. <https://doi.org/10.13031/trans.58.10712>
- Deepika, Nagarathna, Shivshankar, G. P., & Channegowda. (2019). Experimental Investigations on Quality of Water Used in Poultry Farm Using Sensors. In *Lecture Notes in Electrical Engineering* 545, 437–445. Springer Singapore. [https://doi.org/10.1007/978-981-13-5802-9\\_40](https://doi.org/10.1007/978-981-13-5802-9_40)
- Dube, A., Trivedi, J., Solanki, Y. S., Maheshwari, A., & Sharma, A. (2020). Design of an Economical IoT Based Intelligent Lake Water Quality Measuring System with of the Shelf Industrial Grade Sensors. *International Journal of Engineering and Advanced Technology*, 9(3), 30–34. <https://doi.org/10.35940/ijeat.c1008.0393s20>
- Dumlu, E., & Elçi, Ş. (2022). Application of the WASP Model for Assessment of Aeration Impact on Water Quality of Porsuk River, Turkey. *Scientific Research Communications*, 2(2), 1–28. <https://doi.org/10.52460/src.2022.008>
- Fan, C., Ko, C. H., & Wang, W. S. (2009). An innovative modeling approach using Qual2K and HEC-RAS integration to assess the impact of tidal effect on River Water quality simulation. *Journal of Environmental Management*, 90(5), 1824–1832. <https://doi.org/10.1016/j.jenvman.2008.11.011>
- Gu, Y., Li, Y., Yuan, F., & Yang, Q. (2023). Optimization and control strategies of aeration in WWTPs: A review. *Journal of Cleaner Production*, 418, 1–21. <https://doi.org/10.1016/j.jclepro.2023.138008>
- Hakimi, I. M., & Jamil, Z. (2021). Development of Water Quality Monitoring Device Using Arduino UNO. *IOP Conference Series: Materials Science and Engineering* (p. 1144). Batu Pahat, MY. <https://doi.org/10.1088/1757-899x/1144/1/012064>
- Harmel, R. D., Smith, P. K., Migliaccio, K. W., Chaubey, I., Douglas-Mankin, K. R., Benham, B., Shukla, S., Muñoz-Carpena, R., & Robson, B. J. (2014). Evaluating, interpreting, and communicating performance of hydrologic/water quality models considering intended use: A review and recommendations. *Environmental Modelling and Software*, 57, 40–51. <https://doi.org/10.1016/j.envsoft.2014.02.013>
- Hasnol, M. Z., & Zaharuddin, M. F. A. (2020). Development of Aerator for Water Saving. *Jurnal Mekanikal*, 43, 55–64.
- Iqbal, M. M., Shoaib, M., Agwanda, P., & Lee, J. L. (2018). Modeling approach for water-quality management to control pollution concentration: A case study of Ravi River, Punjab, Pakistan. *Water (Switzerland)*, 10(8), 1–20. <https://doi.org/10.3390/w10081068>
- Jayanthi, M., Balasubramaniam, A. A. K., Suryaprakash, S., Veerapandian, N., Ravisankar, T., & Vijayan, K. K. (2020). Assessment of standard aeration efficiency of different aerators and its relation to the overall economics in shrimp culture. *Aquacultural Engineering*, 92(2021), 1–10. <https://doi.org/10.1016/j.aquaeng.2020.102142>
- Jeznach, L. C., Jones, C., Matthews, T., Tobiason, J. E., & Ahlfeld, D. P. (2016). A framework for modeling contaminant impacts on reservoir water quality. *Journal of Hydrology*, 537, 322–333. <https://doi.org/10.1016/j.jhydrol.2016.03.041>
- Jilbert, T., Couture, R. M., Huser, B. J., & Salonen, K. (2020). Preface: Restoration of eutrophic lakes: current practices and future challenges. *Hydrobiologia*, 847(21), 4343–4357. <https://doi.org/10.1007/s10750-020-04457-x>
- Johan, M. F., Abdullah, S., Mohamad Hadis, N. S., Omar, S., & Zanal, A. (2021). Development and Implementation of Water Quality Assessment Monitoring (WQAM) System using the Internet of Things (IoT) in Water Environment. *Journal of Electronic Voltage and Application*, 2(2), 1–12. <https://doi.org/10.30880/jeva.2021.02.02.001>
- Joshi, S., Uttarwar, G., Sawlani, P., & Adlakhe, R. (2020). NodeMCU and Blynk aided Advanced Water Quality Monitoring Set-up. *International Journal of*

- Scientific and Research Publications (IJSRP)*, 10(4), 530–539. <https://doi.org/10.29322/ijsrp.10.04.2020.p10062>
- Juliyanto, M. A., Sulistiyowati, I., Ahfas, A., Juliyanto, M. A., Sulistiyowati, I., & Ahfas, A. (2023). Design of Turbine Aerator with Remote Control and Internet of Things (IoT)-Based Water pH Monitoring. *Buletin Ilmiah Sarjana Teknik Elektro*, 5(1), 156–166. <https://doi.org/10.12928/biste.v5i1.7863>
- Khatri, P., Kumar Gupta, K., & Kumar Gupta, R. (2019). Raspberry Pi-based smart sensing platform for drinking-water quality monitoring system: A Python framework approach. *Drinking Water Engineering and Science*, 12(1), 31–37. <https://doi.org/10.5194/dwes-12-31-2019>
- Lakshmikantha, V., Hiriyanagowda, A., Manjunath, A., Patted, A., Basavaiah, J., & Anthony, A. A. (2021). IoT based smart water quality monitoring system. *Global Transitions Proceedings*, 2(2), 181–186. <https://doi.org/10.1016/j.gltp.2021.08.062>
- Mahdzir, M. M., Yahaya, S. H., Fauadi, M. H. F. M., & Yeow, T. T. (2024). A comprehensive review of water quality control on lentic ecosystem through the water quality, IoT and aeration models. *Multidisciplinary Reviews*, 7(5), 1–26. <https://doi.org/10.31893/multirev.2024098>
- Marappan, J., Ambattaiyanpatti Anathaikamatchi, B., Sakkarai, S., Thiagarajan, R., Muthusamy, D., Kuppusamy, M., Moturi, M., Bera, A., Ramasamy, P., & Shanmugam, S. (2020). Assessment of the new generation aeration systems efficiency and water current flow rate, its relation to the cost economics at varying salinities for *Penaeus vannamei* culture. *Aquaculture Research*, 51(5), 2112–2124. <https://doi.org/10.1111/are.14562>
- Mubarok, M. A., Irawan, R., & Ridwan. (2022). Analysis of Variations of the Number of Blades and Holes of Paddle Wheel Type Aerator at 120-RPM Rotation Speed. *International Conference on Electrical, Computer, Communications and Mechatronics Engineering, ICECCME 2022*. Maldives <https://doi.org/10.1109/ICECCME5909.2022.9988519>
- Mulla, N. H., Krishna, B. M., Manoj Kumar, B., & Professor, A. (2019). A Review on Water Quality Models: QUAL, WASP, BASINS, SWAT and AGNPS. *International Journal of Scientific Research in Civil Engineering*, 3(4), 58–68.
- Munirah, Z. M., Muhammad Izzat Emir, K. B., Wan Maznah, W. O., Teh, S. Y., Ismail, A. H., & Eshak, M. B. (2021). Water quality characteristics and modeling of Tasik Aman, USM, Penang. *IOP Conference Series: Earth and Environmental Science*, 711(1), 1–9. <https://doi.org/10.1088/1755-1315/711/1/012006>
- Nemani, K. S., Peldszus, S., & Huck, P. M. (2023). Practical Framework for Evaluation and Improvement of Drinking Water Treatment Robustness in Preparation for Extreme-Weather-Related Adverse Water Quality Events. *ACS ES and T Water*, 3(5), 1305–1313. <https://doi.org/10.1021/acsestwater.2c00627>
- Nugroho, P. N. A., Mustaghfirin, M. A., Pambudi, D. S. A., Imron, A., Aminudin, M. R., & Wulandari, D. A. (2021). Optimization of Paddle Wheel Aeration, a preliminary study of Integrated Smart Aquaculture System. *Journal of Physics: Conference Series*, 2117, 1–6. <https://doi.org/10.1088/1742-6596/2117/1/012032>
- O’Grady, J., Zhang, D., O’Connor, N., & Regan, F. (2021). A comprehensive review of catchment water quality monitoring using a tiered framework of integrated sensing technologies. *Science of the Total Environment*, 765, 1–12. <https://doi.org/10.1016/j.scitotenv.2020.142766>
- Omofunmi, O. E., Adewumi, J. K., Adisa, A. F., & Aiegbele, S. O. (2017). Development of a paddle wheel aerator for small and medium fish farmers in Nigeria. *AMA, Agricultural Mechanization in Asia, Africa and Latin America*, 48(1), 22–26. <https://doi.org/10.9790/1684-13145056>
- Pak, H. Y., Chuah, C. J., Tan, M. L., Yong, E. L., & Snyder, S. A. (2021). A framework for assessing the adequacy of Water Quality Index – Quantifying parameter sensitivity and uncertainties in missing values distribution. *Science of the Total Environment*, 751, 1–22. <https://doi.org/10.1016/j.scitotenv.2020.141982>
- Pasika, S., & Gandla, S. T. (2020). Smart water quality monitoring system with cost-effective using IoT. *Heliyon*, 6(7), 1–9. <https://doi.org/10.1016/j.heliyon.2020.e04096>
- Ridwan, Irawan, R., & Mubarok, M. A. (2023). Number of holes and blades to control the performance of aquaculture aerator. *Aquaculture and Fisheries*, 8(6), 672–680. <https://doi.org/10.1016/j.aaf.2023.02.007>
- Ridwan, R., Mubarok, M. A., & Irawan, R. (2024). Optimization of Energy Utilization in Aquaculture Ponds by Automation and IoT Monitoring. *Journal of Hunan University (Natural Sciences)*, 51(3), 1–8. <https://doi.org/https://doi.org/10.55463/issn.1674-2974.51.3.2>
- Roshidi, H., & Thirunavakkarasu, P. (2021). The Development of Water Quality Monitoring System at Dam. *Journal of Engineering Technology*, 9(1), 82–85.
- Rostam, N. A. P., Malim, N. H. A. H., Abdullah, R., Ahmad, A. L., Ooi, B. S., & Chan, D. J. C. (2021). A Complete Proposed Framework for Coastal Water Quality Monitoring System with Algae Predictive Model. *IEEE Access*, 9, 108249–108265. <https://doi.org/10.1109/ACCESS.2021.3102044>
- Sahaana, Thanusha, B., Roshanara, S., & Kaviya, M. (2022). Water monitoring and conservation in tanks by effective methodology using raspberry PI. *International Journal of Health Sciences*, 6(3), 7580–7587. <https://doi.org/10.53730/ijhs.v6ns3.7733>
- Samaneh Abdeveis, Sedghi, H., Hassonizadeh, H., & Babazadeh, H. (2020). Application of Water Quality Index and Water Quality Model QUAL2K for Evaluation of Pollutants in Dez River, Iran. *Water Resources*, 47(5), 892–903. <https://doi.org/10.1134/S0097807820050188>
- Satra, R., Hadi, M. S., Sujito, S., Febryan, F., Fattah, M. H., & Busaeri, S. R. (2024). IoT: Internet of Aquaculture Things for Monitoring Water Temperature in Tiger Shrimp Ponds with DS18B20 Sensors and WeMos D1 R2. *Journal of Robotics and Control (JRC)*, 5(1), 62–71. <https://doi.org/10.18196/jrc.v5i1.18470>
- Sharma, N., & Kaushal, A. (2021). Assessing Water Quality Models for Surface Water Resources : A Review Assessing Water Quality Models for Surface Water Resources : A Review. *Journal of Soil Salinity and Water Quality*, 13(2), 135–146.
- Sinha, E., Michalak, M., & Alaji, V. (2017). Eutrophication will increase over the 21 st century due to precipitation changes. *Science*, 357(6349), 405–408. <https://doi.org/10.1126/science.aan2409>
- Sivakumar, S., & Ramya, V. (2021). An Intuitive Remote Monitoring Framework for Water Quality in Fish Pond using Cloud Computing. *IOP Conference Series: Materials Science and Engineering*, 1085, 1–9. Kanjirapally, IND. <https://doi.org/10.1088/1757-899x/1085/1/012037>
- Srinivas, R., & Singh, A. P. (2018). An integrated fuzzy-based advanced eutrophication simulation model to develop the best management scenarios for a river basin. *Environmental Science and Pollution Research*, 25(9), 9012–9039. <https://doi.org/10.1007/s11356-018-1206-0>
- Suteja, Y., & Dirgayusa, I. G. N. P. (2018). Detection of Eutrophication In Benoa Bay - Bali. *Omni-Akuatika*, 14(3), 18–25. <https://doi.org/10.20884/1.oa.2018.14.3.490>
- Tanveer, M., Roy, S. M., Vikneswaran, M., Renganathan, P., & Balasubramanian, S. (2018). Surface aeration systems for application in aquaculture: A review. *International Journal of Fisheries and Aquatic Studies*, 6(5), 342–347. <http://www.fisheriesjournal.com/archives/2018/vol6issue5/PartE/6-5-23-591.pdf>
- Tsai, K. L., Chen, L. W., Yang, L. J., Shiu, H., & Chen, H. W. (2022). IoT based Smart Aquaculture System with Automatic Aerating and Water Quality Monitoring. *Journal of Internet Technology*, 23(1), 177–184. <https://doi.org/10.53106/160792642022012301018>
- Wimordi, C., Yudianto, D., & Guan, Y. (2021). Application of WASP model to simulate water pollution control of Duriangkang Dam. *Lakes and Reservoirs: Science, Policy and Management for Sustainable Use*, 26(1), 23–32. <https://doi.org/10.1111/lre.12350>
- Xiong, H., Liu, T., Wang, H., & Feng, C. (2022). Simulation of the improving effect of graphene visible-light photocatalysis using the MIKE11 model of an urban

landscape river in the Chaohu Lake Basin, China. *Natural Resource Modeling*, 35(3), 1–18. <https://doi.org/10.1111/nrm.12344>

Yang, L. E., Chan, F. K. S., & Scheffran, J. (2018). Climate change, water management and stakeholder analysis in the Dongjiang River basin in South China. *International Journal of Water Resources Development*, 34(2), 166–191. <https://doi.org/10.1080/07900627.2016.1264294>

Zehra, R., Singh, S. P., Verma, J., & Kulshreshtha, A. (2023). Spatio-temporal investigation of physico-chemical water quality parameters based on comparative assessment of QUAL 2Kw and WASP model for the upper reaches of Yamuna River stretching from Paonta Sahib, Sirmaur district to Cullackpur, North Delhi districts. *Environmental Monitoring and Assessment*, 195(4), 1–14. <https://doi.org/10.1007/s10661-023-11072-5>