

Innovative design of a directional control valve using shape memory alloy to control fluid flow



Suraj^a  | Arun Kumar^a

^aDepartment of Mechanical Engineering, National Institute of Technology Patna, Patna Bihar, India.

Abstract Direct control valves (DCVs) are essential components in various industrial processes, enabling the precise regulation of fluid flow, whether it involves liquids or gases. These valves play a pivotal role in controlling critical system parameters, such as pressure, temperature, and flow rate, to ensure optimal performance and safety. Traditional directional control valves often utilize mechanical or electromechanical actuators, which can be complex and prone to wear over time, leading to potential inefficiencies and maintenance challenges. There is a growing need for a simpler, more efficient design that offers accurate and predictable control over the direction of fluid flow. Such a system would reduce mechanical complexity while maintaining the ability to prevent unintended movements within the system. This research paper explores the design theory of a directional control valve device utilizing a zig-zag shaped sheet made of a Shape Memory Alloy (SMA), which undergoes oneway training, achieving a trained zig-zag shape, thereby influencing an actuation behavior. In an absence of heating, the configured expanded state exerts a force to maintain a specific position within the valve. Actuation occurs by selectively applying heat through an embedded electrical resistance element, causing the sheet to contract and move a mechanically coupled piston. The piston's movement controls fluid flow direction. Unidirectional actuation is achieved through SMA zig-zag sheet's oneway training, where sheet contraction performs mechanical work against piston force to provide a precise fluid flow control, enabling applications in diverse industries such as robotics and automation. This paper details the design, operation, and advantages of the SMA operated directional control valve, presenting it as a superior alternative to traditional control valves.

Keywords: innovative technologies, development design, design & engineering, electronic and mechanical systems

1. Introduction

Directional control valves (DCVs) are essential for regulating fluid flow in various industrial processes. Traditional DCVs use mechanical or electromechanical actuators, which often introduce issues such as high energy consumption, maintenance challenges, and limited precision. Actuators in DCVs, available in pneumatic, electric, and hydraulic types, are responsible for moving the valve mechanism in response to control signals. However, the complexity and susceptibility to wear of these systems necessitate an improved solution.

Shape memory alloys (SMAs) offer a unique solution to these challenges. SMAs can return to a predefined shape when heated above a certain temperature (Collazo et al., 2021). This property is harnessed in various applications, from medical devices to actuators (Chaudhary et al., 2024; Zareie et al., 2020). In this study, we explore the potential of using SMAs in the operation of directional control valves to provide a more efficient, reliable, and precise control mechanism. The device comprises a corrugated sheet that is made up of a Shape Memory Alloy (SMA) and is shaped into a zig-zag shape by being subjected to heating to a high temperature. Said SMA zig-zag sheet is configured to exert a force upon contraction. The device also comprises a piston, wherein the SMA zig-zag sheet causes the piston to move upon an actuation process produced through heating. The movement of the piston controls a flow direction of the fluid within the DCV. The heating is produced by a means for heating that induces contraction and actuation on the SMA zig-zag sheet to control the flow direction of the fluid. The device also comprises a housing, which encloses the SMA zig-zag sheet, the piston, and the means for heating.

Ni-Ti-based alloys, which contain 48–52% nickel by weight, are particularly valued for their shape-memory and pseudo-elastic effects. These alloys are characterized by a broad plateau and significant stress hysteresis, as well as good workability in the martensite phase and excellent resistance to corrosion and fatigue (Hartl & Lagoudas, 2007). The primary objectives of this innovative design are to achieve precise and reliable control over the fluid flow direction, ensure unidirectional actuation to maintain control and prevent unintended movements, optimize energy usage by minimizing power consumption during inactivity, and provide a compact and lightweight design suitable for space- and weight-sensitive applications.

2. Literature Review



Traditional Control Valves: Traditional control valves, including needle valves and control valves such as those described in patents (Chen et al., 2000; Elliott et al. 2016), utilize mechanical or electromechanical systems to regulate fluid flow. These systems often rely on complex assemblies of springs, diaphragms, solenoids, and pistons. While effective, they present several limitations. **Energy consumption:** Electromechanical actuators, particularly solenoids, require continuous power to maintain their position, leading to high energy consumption. **Maintenance:** Mechanical components are prone to wear and tear, requiring regular maintenance to ensure consistent performance. **Size and Weight:** The complexity of these systems often results in bulky and heavy designs, limiting their application in space-constrained environments.

Shape memory alloys (SMAs), particularly nickel titanium naval order laboratories (Nitinol) alloys, exhibit unique properties that make them suitable for actuation purposes (Kauffman & Mayo, 1997). **Shape Memory Effect:** SMAs can "remember" their original shape and return to it when heated above a specific transformation temperature (Mohd Jani et al., 2014). **Superelasticity:** SMAs can undergo significant deformation and recover their original shape upon unloading, which is beneficial for applications requiring repeated actuation (Isidoro et al., 2021 & Kim et al., 2023). **Corrosion resistance:** Nitinol is highly resistant to corrosion, increasing the durability of devices operating in harsh environments.

Application of SMAs in Control Valves: The use of SMAs in control valves is relatively novel (Lagoudas, 2008; Sun et al., 2012; Namazu et al., 2006; Basit et al., 2013; Takashima et al., 2014; Pimpin et al., 2004; Pelrine et al., 1998; Chen & Liu, 2013; Jayaram et al., 2018; Grunwald & Olabi, 2008; Hong, 2013). Previous attempts have shown potential but have been limited by the ability to precisely control the shape memory effect and the integration of SMA components with traditional valve mechanisms. This research aims to overcome these challenges by developing a control valve that leverages the SMA's unique properties to enhance performance and reliability.

3. Methodology

3.1. Device Design

The device comprises several key components: the SMA Zig-Zag Sheet, which is a corrugated sheet made of SMA (Nitinol) shaped into a Zig-Zag form through a one-way training process. **Piston:** Mechanically coupled to the SMA sheet, it moves upon actuation through the external input of heat to control the fluid flow direction. **Means for Heating:** Includes embedded electrical resistance heating elements to induce contraction of the SMA sheet. **Housing:** The SMA sheet, piston, and heating elements are enclosed, providing structural support and protection (Figure 1). The Dassault System's SOLIDWORKS 2019 SP2 is used for the design.

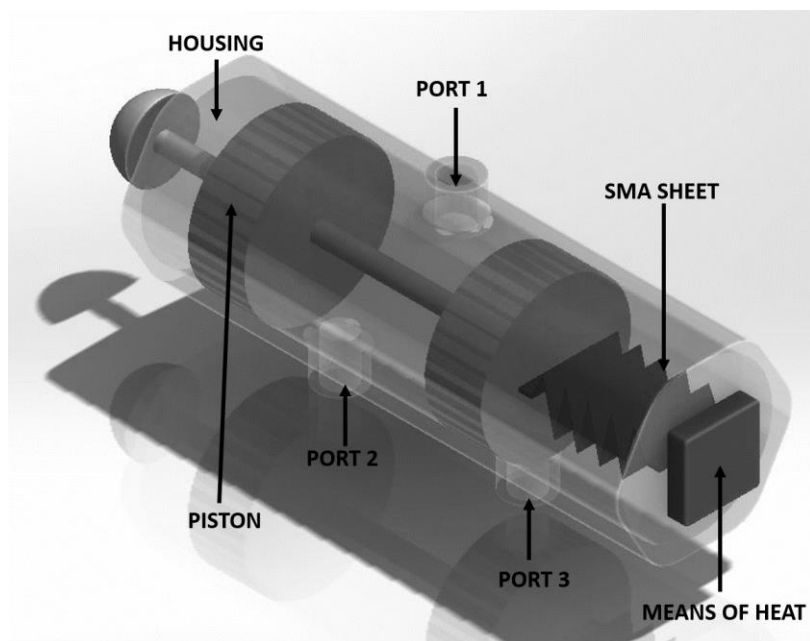

Figure 1 Illustration of the directional control valve.

3.2. One-way training process

The SMA sheet undergoes a one-way training process, as shown in Figure 2, to ensure predictable and repeatable actuation. The SMA sheet is heated to approximately 550°C to induce a phase transformation from martensite to austenite. In the austenite phase, the sheet deformed into a Zig-Zag shape and then cooled to retain this shape. The heating and cooling cycles are repeated to enhance the memory effect and ensure consistent actuation.

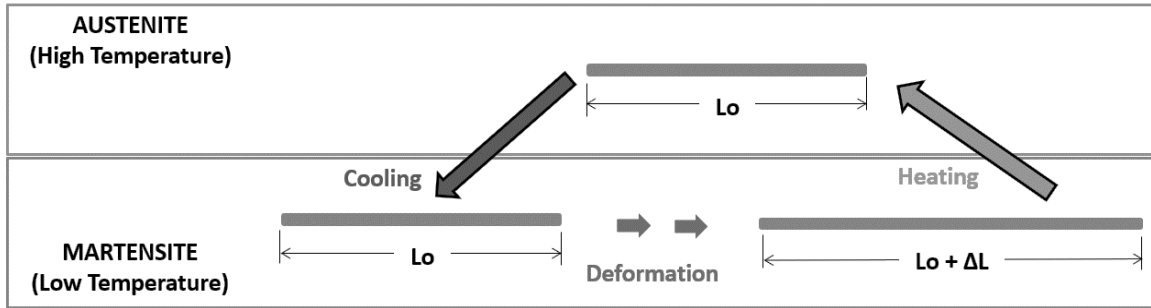

Figure 2 Oneway training process.

3.3. Actuation mechanism

The actuation process leverages the shape memory effect of the SMA (Figure 3). The electrical resistance heating elements embedded within the housing selectively heat the SMA Zig-Zag sheet. Upon heating, the SMA sheet contracts, exerting a mechanical force on the piston. The piston moves in response to the force exerted by the contracting SMA sheet, controlling the directional flow of the fluid. When the heating elements are deactivated, the SMA sheet cools and returns to its original shape, resetting the piston to its initial position (Figure 4). Flow chart of the method for operating the directional control valve in Figure 5.

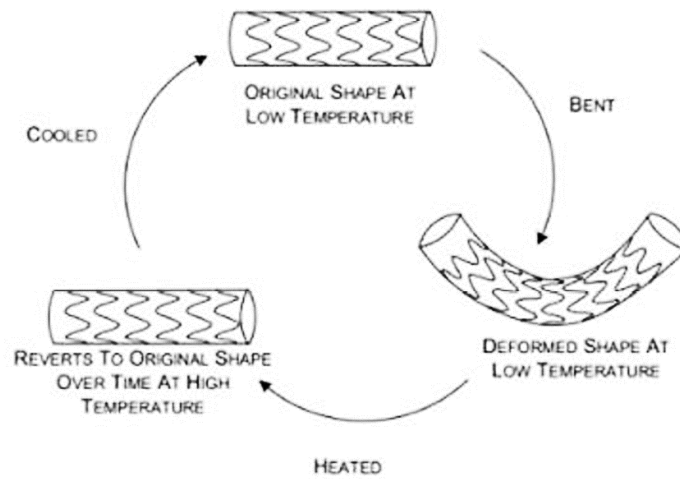

Figure 3 Block diagram of the shape memory effect in the device.

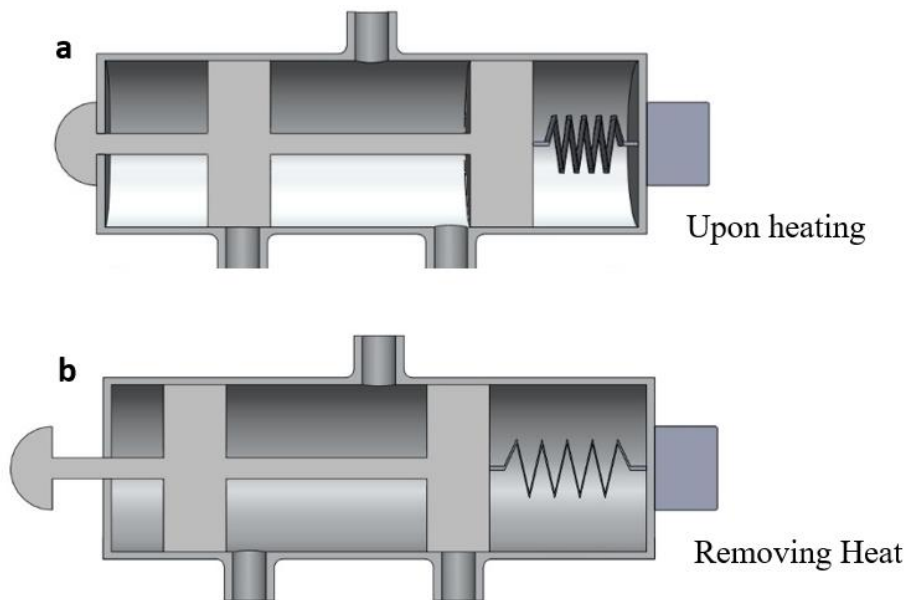

Figure 4 Diagram showing actuation of the SMA sheet a. upon heating and b. removing heat.

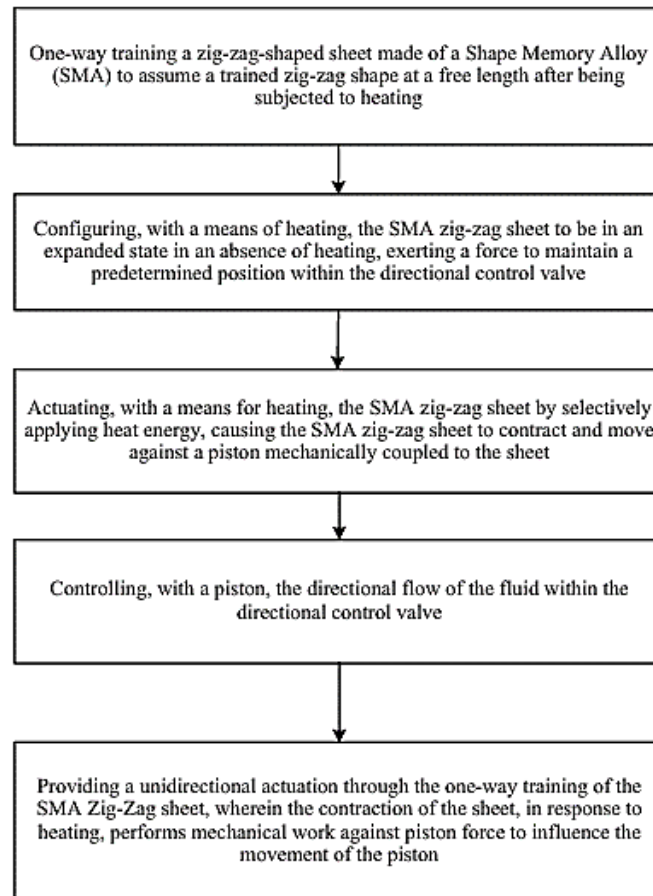

Figure 5 Method for operating the directional control valve.

4. Results and Discussion

The performance of the SMA-operated directional control valve was evaluated on the basis of several criteria, including precision, reliability, energy efficiency, and design compactness.

The trained SMA sheet provides consistent and repeatable actuation, ensuring precise control over the fluid flow direction. The device exhibited minimal hysteresis, allowing accurate control signals to be translated into predictable valve movements. (Nath et al., 2015) The reliability of the device was further enhanced by the corrosion resistance of Nitinol, which reduced the likelihood of degradation in harsh operating environments. Compared with that of traditional control valves, the energy efficiency of the device was significantly improved. The SMA-operated valve required energy input only during the heating phase, with no power consumption during inactivity. This selective heating approach minimizes energy usage, making the device suitable for applications where energy efficiency is paramount. The use of the SMA allows for a compact and lightweight design, reducing the overall footprint of the device. This makes it particularly suitable for applications with space and weight constraints, such as aerospace and medical devices. The simplified design also reduced the number of components susceptible to wear, further enhancing the device's reliability and lifespan (Mani Prabu et al., 2019). A comparative study was conducted to evaluate the performance of the SMA-operated directional control valve against traditional control valves. The study considered factors such as energy consumption, maintenance requirements, control precision, and overall reliability.

The premise design viz. Traditional control valves, particularly those using electromechanical actuators, exhibit higher energy consumption because of the continuous power requirements to maintain valve positions. In contrast, the SMA-operated valve demonstrated significant energy savings by requiring power only during the heating phase. This reduction in energy consumption contributed to lower operational costs and enhanced sustainability. The mechanical complexity of traditional control valves often necessitates regular maintenance to address wear and tear. The SMA-operated valve, with its simplified design and fewer moving parts, reduces the frequency and complexity of maintenance activities. The inherent corrosion resistance of Nitinol further minimizes maintenance needs, increasing the device's operational lifespan (Disawal et al., 2018). The precision of the SMA-operated valve was superior to that of traditional valves because of the predictable and repeatable nature of the SMA actuation mechanism. The reduced hysteresis and consistent performance of the SMA sheet allowed accurate control over the fluid flow direction, improving process efficiency and reducing the likelihood of errors. The reliability of the SMA-operated valve was enhanced by the durable properties of Nitinol and the reduction in mechanical

components prone to failure. Traditional valves, with their complex assemblies, are more susceptible to mechanical failure and require more frequent repairs. The SMA-operated valve design focused on robustness and longevity, ensuring reliable performance over extended periods.

5. Conclusion

This research introduces a novel SMA-operated directional control valve that addresses the limitations of traditional control systems. The device offers precise, reliable, and energy-efficient control over fluid flow, with a compact design suitable for various industrial applications. The oneway training process of the SMA sheet ensures consistent and repeatable actuation, whereas the selective heating approach optimizes energy usage. The simplified design reduces the maintenance requirements and enhances the overall reliability and lifespan of the device. Future work will focus on optimizing the training process of the SMA sheet and exploring additional applications of this technology. Potential areas for further research include the integration of SMA-operated valves in complex fluid control systems and the development of advanced control algorithms to increase the precision and responsiveness of the device.

Acknowledgment

I would like to express my heartfelt gratitude to the National Institute of Technology Patna for providing me with excellent research facilities and resources. The support and guidance from the faculty and staff, especially to my mentor Dr. Amit Kumar, Professor, Department of Mechanical Engineering, NIT Patna, have been invaluable throughout my research journey. Special thanks to my family, my support system and my twins, Vrishank and Vyom for their constant encouragement and support, which significantly contributed to the successful completion of this work.

Ethical considerations

Not applicable.

Conflict of interest

The authors declare that they have no conflicts of interest.

Funding

This research did not receive any financial support.

References

- Basit, A., L'Hostis, G., & Durand, B. (2013). High actuation properties of shape memory polymer composite actuator. *Smart Materials and Structures*, 22.
- Chaudhary, K., Haribhakta, V. K., & Jadhav, P. V. (2024). A review of shape memory alloys in MEMS devices and biomedical applications. *Materials Today: Proceedings*. <https://doi.org/10.1016/j.matpr.2024.04.105>
- Chen, S. K., & Hefler, G. W. (2000). Hydraulically actuated fuel injector with direct control needle valve. <https://patents.google.com/patent/US6065450A/en>
- Chen, W. M., & Liu, T. S. (2013). Modeling and experiment of three-degree-of-freedom actuators using piezoelectric buzzers. *Smart Materials and Structures*, 22(10), 105006. <https://doi.org/10.1088/09641726/22/10/105006>
- Collazo, A., Figueroa, R., Mariño-Martínez, C., & Pérez, C. (2021). Microstructure and thermomechanical characterization of Fe₂₈Mn₆Si₅Cr shape memory alloy. *Metals*, 11(4), 649–649. <https://doi.org/10.3390/met11040649>
- Disawal, R., Nath, T., Prakash, S., & Palani, I. A. (2018). Life cycle analysis of electrically actuated SMA spring using Talbot interferometry. *Applied Optics*, 57(20), 5779. <https://doi.org/10.1364/ao.57.005779>
- Elliott, D., Grace, A., McHugh, E., & O'Donnell, M. (2016). Control valve. <https://patents.google.com/patent/US9482347B2/en>
- Grunwald, A., & Olabi, A. (2008). Design of a magnetostrictive (MS) actuator. *Sensors and Actuators A: Physical*, 144(1), 161–175. <https://doi.org/10.1016/j.sna.2007.12.034>
- Hartl, D. J., & Lagoudas, D. C. (2007). Aerospace applications of shape memory alloys. *Proceedings of the Institution of Mechanical Engineers, Part G: Journal of Aerospace Engineering*, 221(4), 535–552. <https://doi.org/10.1243/09544100jaero211>
- Hong, C. (2013). Application of a magnetostrictive actuator. *Materials & Design (1980–2015)*, 46, 617–621. <https://doi.org/10.1016/j.matdes.2012.11.013>
- Isidoro, D., Hartloper, A., Albano, L., Lignos, D. G., Motavalli, M., & Ghafoori, E. (2021). Experimental behavior of iron-based shape memory alloys under cyclic loading histories. *Construction and Building Materials*, 272, 121712–121712. <https://doi.org/10.1016/j.conbuildmat.2020.121712>
- Jayaram, K., Jafferis, N. T., Doshi, N., Goldberg, B., & Wood, R. J. (2018). Concomitant sensing and actuation for piezoelectric microrobots. *Smart Materials and Structures*, 27(6), 065028. <https://doi.org/10.1088/1361665x/aabdf1>
- Kauffman, G. B., & Mayo, I. (1997). The story of Nitinol: The serendipitous discovery of the memory metal and its applications. *The Chemical Educator*, 2(2), 1–21. <https://doi.org/10.1007/s00897970111a>
- Kim, M., Heo, J., Rodrigue, H., Lee, H., Pané, S., Han, M., & Ahn, S. (2023). Shape memory alloy (SMA) actuators: The role of material, form, and scaling effects. *Advanced Materials*. <https://doi.org/10.1002/adma.202208517>
- Lagoudas, D. C. (2008, June 5). *Shape memory alloys*. Springer Science & Business Media.

- Mani Prabu, S. S., Mithun, R., Muralidharan, M., Nath, T., Brolin, A., Akash, K., & Palani, I. A. (2019). Thermomechanical behavior of shape memory alloy spring actuated using novel scanning technique powered by ytterbium doped continuous fiber laser. *Smart Materials and Structures*, 28(4), 047001. <https://dx.doi.org/10.1088/1361-665X/ab06d8>
- Mohd Jani, J., Leary, M., Subic, A., & Gibson, M. A. (2014). A review of shape memory alloy research, applications and opportunities. *Materials & Design (1980–2015)*, 56, 1078–1113. <https://doi.org/10.1016/j.matdes.2013.11.084>
- Namazu, T., Tashiro, Y., & Inoue, S. (2006). Ti–Ni shape memory alloy film-actuated microstructures for a MEMS probe card. *Journal of Micromechanics and Microengineering*, 17, 154–162.
- Nath, T., Kasliwal, A., Kulkarni, K., Singh, R., Khatri, R., Raut, G., Kumar, A., Mittal, S., & Palani, I. A. (2015). Investigation on the laser-based actuation of single-way trained SMA sheet and their application for the development of micro positioning stage. *Applied Mechanics and Materials*, 766–767, 427–431. <https://doi.org/10.4028/www.scientific.net/amm.766-767.427>
- Pelrine, R., Kornbluh, R., & Joseph, J. (1998, January 1). Electrostriction of polymer dielectrics with compliant electrodes as a means of actuation. [https://doi.org/10.1016/s09244247\(97\)016579](https://doi.org/10.1016/s09244247(97)016579)
- Pimpin, A., Suzuki, Y., & Kasagi, N. (2004). Micro electrostrictive actuator with metal compliant electrodes for flow control applications. *17th IEEE International Conference on Micro Electro Mechanical Systems. Maastricht MEMS 2004 Technical Digest*. <https://doi.org/10.1109/mems.2004.1290626>
- Sun, L., Huang, W., Ding, Z., Zhao, Y., Wang, C. C., Purnawali, H., & Tang, C. (2012, January 1). Stimulus-responsive shape memory materials: A review. *Materials & Design*. <https://doi.org/10.1016/j.matdes.2011.04.065>
- Takashima, K., Sugitani, K., & Morimoto, N. (2014). Pneumatic artificial rubber muscle using shape-memory polymer sheet with embedded electrical heating wire. *Smart Materials and Structures*, 23(12), 125005. <https://doi.org/10.1088/09641726/23/12/125005>
- Zareie, S., Issa, A. S., Seethaler, R. J., & Zabihollah, A. (2020). Recent advances in the applications of shape memory alloys in civil infrastructures: A review. *Structures*, 27, 1535–1550. <https://doi.org/10.1016/j.istruc.2020.05.058>